

Heating

INTRODUCTION

THE PURPOSE OF A HEATING SYSTEM IS OBVIOUS. HOW WELL A HEATING SYSTEM PERFORMS IS NOT SO OBVIOUS. A WELL-DESIGNED HEATING SYSTEM IS LARGE ENOUGH TO PROVIDE ADEQUATE HEAT ON THE COLDEST DAY, IS RELIABLE, IS INEXPENSIVE TO INSTALL AND OPERATE (EFFICIENT), IS QUICK TO RESPOND TO ITS CONTROLS, CAN HEAT ALL PARTS OF THE HOME EQUALLY OR DIFFERENTIALLY, AND IS SAFE. THERE IS NO ONE HEATING SYSTEM THAT PERFORMS ALL OF THESE FUNCTIONS PERFECTLY.

OUR DISCUSSION IN THIS CHAPTER WILL ASSUME THAT WE ARE IN COLD CLIMATES WHERE HEATING IS NEEDED SEVERAL MONTHS A YEAR.

1.0 Heating Objectives

Simply put, the goal is to generate and distribute heat through the home. The heat is often generated centrally, in a furnace or boiler, and is distributed by air through ducts or by water in pipes. If the heat from the gas, oil, or electricity is transferred to air, the system is called a furnace. Where water is the heat transfer medium, this is a boiler. Any fuel can be used with either distribution system.

We can also generate heat in each room and have no distribution system. The most common example is electric baseboard heaters.

2.0 Generating Heat

2.1 Fuel

Several fuels can be used to generate the heat. Oil, natural gas and propane are fossil fuels that are burned. Wood is also burned. Electricity generates heat by passing current through coils or wires. Heat pumps and solar heating for example collect existing heat and release it into the home. Fuel choices are based on fuel availability, cost, efficiency (how much of the heat generated can be used), and the cost and durability of the heating equipment.

Let's look at some of the fuel delivery systems.

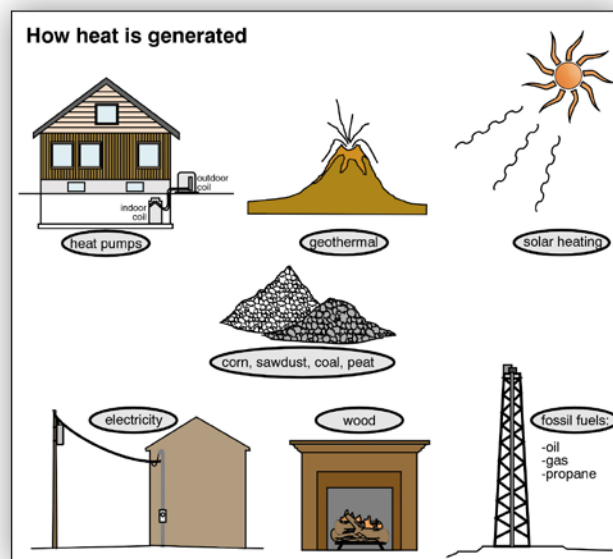

2.2 Gas (Natural Gas or Propane)

DESCRIPTION **2.2.1 Natural Gas Piping:** Homes with natural gas have underground piping that delivers gas to the house from a utility's distribution network.

BURIED PIPING Underground piping can be steel, copper or plastic. Where steel piping is used underground, it should be protected from rusting with coatings or wraps that cover the pipe underground and up to six inches above grade. Some areas also require cathodic protection (a sacrifice material that rusts to protect the gas piping).

Where plastic pipe is used underground, the plastic should not be visible or exposed to mechanical damage. Risers that extend above grade should be metal. A copper tracer wire is typically laid with the pipe to help the gas company find it later, when someone wants to dig in the area. The wire should be visible on the above grade section of the pipe.

PIPING IN THE HOME Gas piping indoors should be steel, copper or corrugated stainless steel tubing (CSST). The steel tubing is coated with a PVC plastic exterior. Copper is not permitted in some areas because sulfur in the natural gas can react with the copper.

PIPE SUPPORT Gas piping should be well supported, and there should be no strain on the connections. The gas piping should not be used to support appliances. The illustration here shows support requirements for steel piping.

METERS Meters may be inside or outside the house. Most gas meters on new construction are on the exterior, since this is more convenient for the utility and is arguably a safer location. Meters usually have an isolating valve so that the gas can be shut off. The meter and shut-off valve should always be accessible, both for the convenience of the gas company and for safety. Meters should be protected from mechanical damage from vehicles.

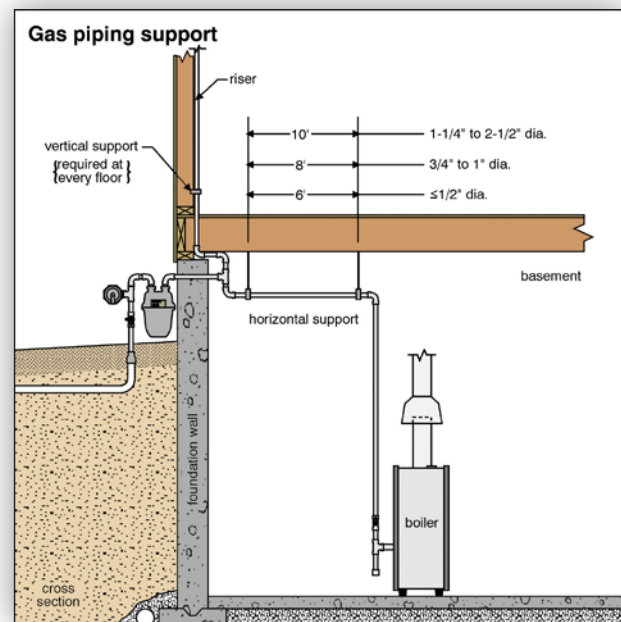

Meters may have a regulator to provide the right gas pressure for the home. These discharge gas into the atmosphere through a relief vent. Regulators should vent to the outside, at least three feet from sources of ignition, windows, doors and appliance intakes or exhausts, and at least ten feet from mechanical air intakes.

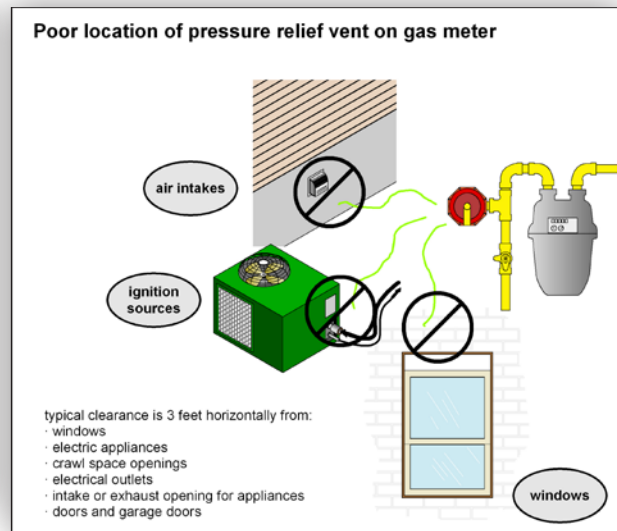
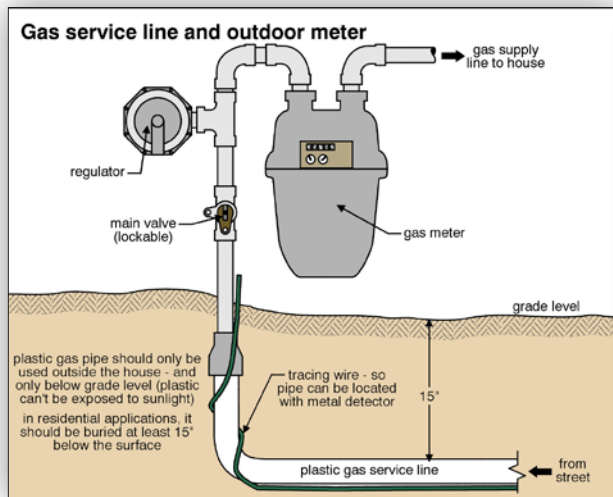

APPLIANCE CONNECTIONS Where appliances are connected, there should be a shut-off valve in the same room for each appliance, as close to the appliance as practical. This allows things to be shut off quickly in the event of an emergency. Piping connections should not be in concealed areas (walls, attic, etc.).

Appliance connectors (flexible metal piping) can be used in some areas. Direct connection is considered superior, except where earthquake is a concern. Connectors, for the most part, should be two feet long, although range or dryer connectors can be six feet long. The connectors should not pass through walls, floors or ceilings, and should be immediately preceded by a shut-off valve.

Where there are gas outlets for barbecues or fireplaces, the valves should be outside the hearth and in the same room as the appliance.

GROUNDING AND BONDING

Gas piping should not be used to ground the electrical system; however, metal gas piping is typically bonded to supply piping (usually at the water heater) or something else that is connected to ground. The bonding prevents the gas piping from becoming a dangerous electrical conductor if a live wire touches the piping.

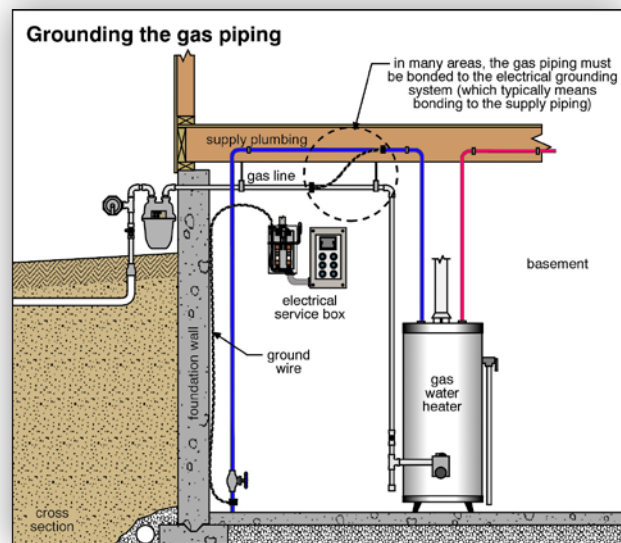
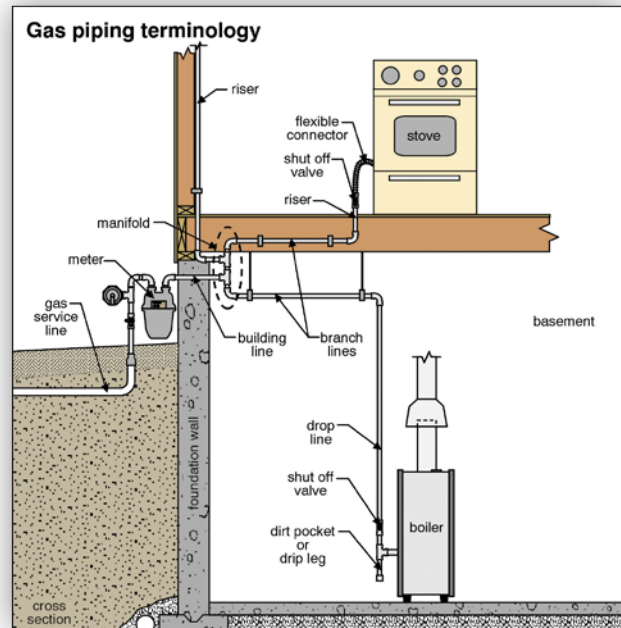

DRIP LEGS Many jurisdictions require a vertical pipe extension (drip leg) below the elbow where the horizontal pipe feeds an appliance. Any foreign material or moisture in the gas coming toward the appliance will drop into the drip leg, rather than turn and head into the burner.

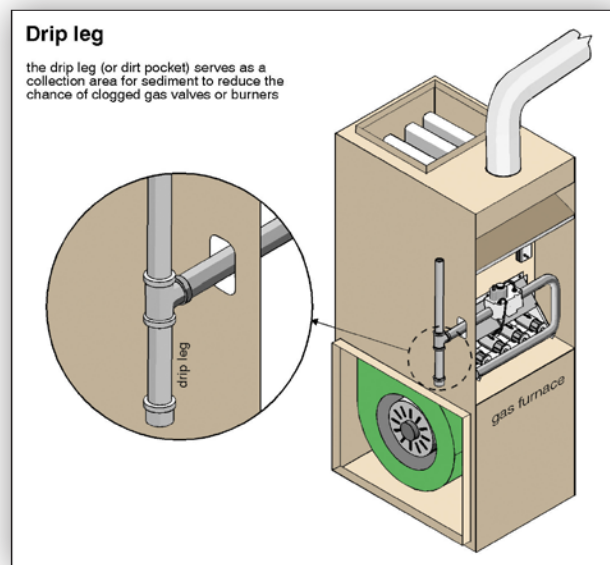

Common Problems with Gas Piping

LEAKS Any gas leak is a potentially life threatening situation. If a leak is noted, all occupants should leave the house immediately and contact the gas company. No switches, telephones including cell phones, door bells, or anything else that might cause a spark should be operated.

Leaks are usually noted by the odor. Natural gas is odorless, but a perfume is added to it so we can smell a leak.

INAPPROPRIATE MATERIAL Plastic gas piping should not be exposed above ground or inside the building. In some areas, copper gas piping is not permitted.

INADEQUATE SUPPORT Where gas piping is not well supported, improvements should be made promptly.

DRIP LEG MISSING Drip legs catch foreign material before they get into burners. Missing drip legs should be provided by a specialist.

2.2.2 Propane Tanks : Propane and natural gas are very similar, but their delivery methods are different. Natural gas is carried to the home through a utility network of pipes. Propane is delivered by truck to a propane storage tank outdoors on the property. Propane is stored as a liquid that turns into a gas as pressure is released. Many people are familiar with propane used on gas barbecues. The tanks are only filled to roughly 80% capacity, allowing room for expansion.

Propane tanks may be installed above ground or below grade. We will focus on above grade tanks here, since underground tanks cannot be seen. Propane tanks should be approved for their use, and should be mounted on any stable surface. They should be protected from mechanical damage.

SERVICE PIPING/ YARD LINE	Pipe running from the tank to the furnace is buried 12 to 18 inches under the ground. It is typically copper or polyethylene. Copper is not permitted in all jurisdictions. The service piping may be run underground in a PVC sleeve, for example for added protection.
TANK LOCATION	Tank location is determined in part by the size of the tank. Most tanks are at least 10 feet from buildings, property lines and sources of ignition. Tanks should not be covered by roofs, awnings or overhangs, since relief valves discharge propane straight up.
JURISDICTIONS MAY HAVE THEIR OWN RULES	Requirements for installation including location and materials used can vary significantly among municipalities. Propane tank and service line installations are usually subject to permits from local authorities.

Common Problems with Propane Tanks

TOO CLOSE TO BUILDINGS IGNITION SOURCES	Tanks should typically be 10 feet from walls, windows, air conditioners, appliance intake vents, etc. A specialist should be consulted where there is uncertainty.
UNDER ROOF/ AWNING/ OVERHANG	Propane tanks should not be installed below any structure. Propane that is being vented may collect, creating an explosion hazard.
DESCRIPTION	2.2.3 Gas Burners: Gas burners can be either propane or natural gas, so we will treat them as the same. A gas burner is fed from an electrically operated valve that allows gas to enter the burner where it is mixed with air and ignited. The most common gas burners are, ribbon burners, monoport burners and ring burners. Since gas is dangerous, there are several safety devices associated with burners.

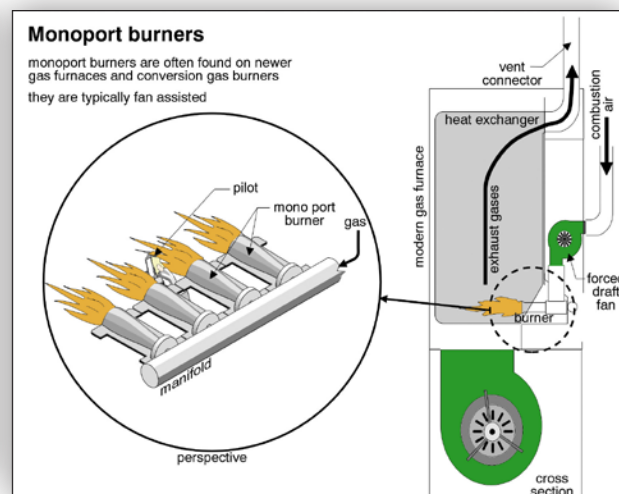
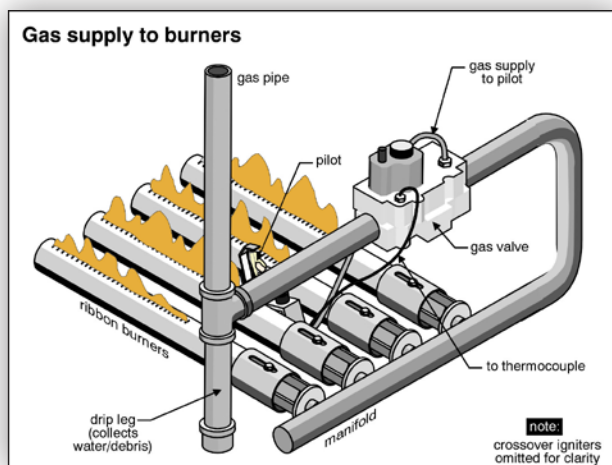

TWO-STAGE FURNACES (MODULATING) FURNACES Traditional furnaces only have one speed. They are either on or off. Many modern furnaces can operate at a low and a high firing rate. This improves efficiency and helps to reduce heating costs. These may be referred to as two-stage or modulating furnaces.

Common Problems with Gas Burners

DIRTY/ MISALIGNED/ RUSTED Burners get dirty and the small orifices (particularly on ribbon burners) plug with debris. Burners also become misaligned and the flame may not point in the right direction. Burners can also rust, especially if humidifiers or air conditioners above leak into the furnace, or if the exhaust gases condense in the furnace.

INCOMPLETE COMBUSTION Natural gas needs lots of air to burn properly. The restricted air supply results in incomplete combustion, higher heating costs, and, in some cases, condensation problems. In severe cases, carbon monoxide poisoning may occur.

FLASHBACK (BACKDRAFTING) On some heating systems (particularly with ribbon burners) “flashback” is a common problem when the system first starts up. Some of the ignited gas spills out of the front of the heating system. Heat shields, provided on most systems, prevent any serious damage under these conditions; however, in extreme cases, control wiring and other components of the heating system may be scorched.

DESCRIPTION 2.2.4 Gas Valve: The gas valve contains most of the brains of the heating system. The electrically operated valve opens and allows gas into the combustion chamber, after making sure it is safe to do so.

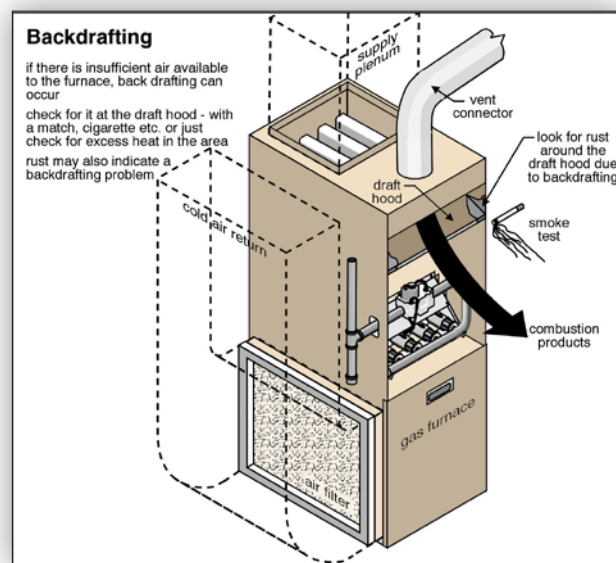

Common Problems with Gas Valves

INOPERATIVE The most common problem is failure to operate. Gas valves always fail in the closed position for obvious safety reasons. They are fail-safe devices. Failure to open may be the result of safety devices doing their job.

GAS LEAK Gas leaks are not common but are serious. If natural gas is smelled, the occupants should leave the house immediately and contact the utility from outside the home. No telephones including cell phones, computers or other devices that may generate a spark should be used in the home.

DESCRIPTION **2.2.5 Heat Shield:** A heat shield, found on most conventional forced-air furnaces is a metal plate designed to prevent the flames from coming out the front of the burner. The heat shield is not normally removed during a home inspection.

MISSING/OUT OF PLACE/RUST The heat shield may be loose, out of place, rusted, or missing. Where there is evidence of scorching on the heat shield, a service specialist should be engaged to investigate.

2.2.6 Ignition Systems: Ignition systems light the burner and may be pilot, spark or hot surface systems. There will be no heat in the house if the ignition system is defective. It is unusual for home inspectors to find problems with ignition systems, since the heating system will not operate. Troubleshooting heating systems is not within the scope of a professional home inspection.

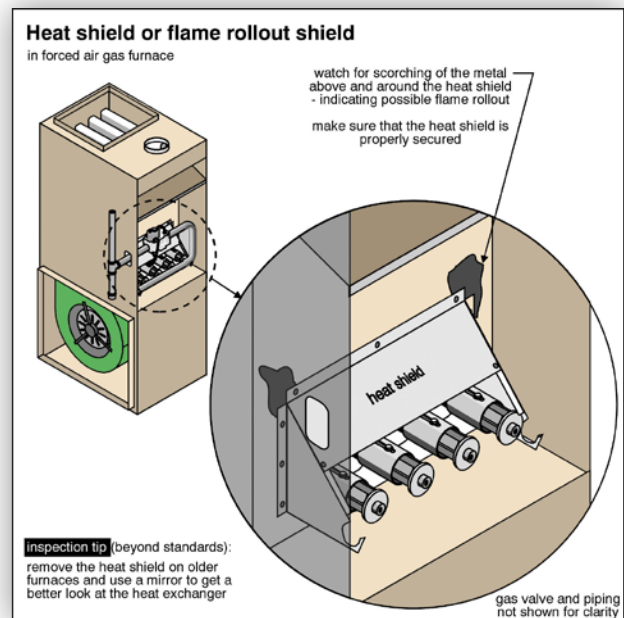

2.2.6.1 Pilot/Thermocouple:

Many older gas-fired heating systems have a continuous pilot. The pilot lights the burner when the gas valve opens. The thermocouple makes sure the pilot is on before allowing the gas valve to open.

2.2.6.2 Intermittent Pilot/Electronic Ignition:

Newer systems have an intermittent pilot that is ignited by a spark plug. Pilot ignition is verified by a thermocouple. If the pilot does not light after a few attempts, the heating system shuts down.

High efficiency gas systems typically use a hot surface ignition system instead of a pilot. These systems have a flame sensor to shut down the system if ignition is not detected.

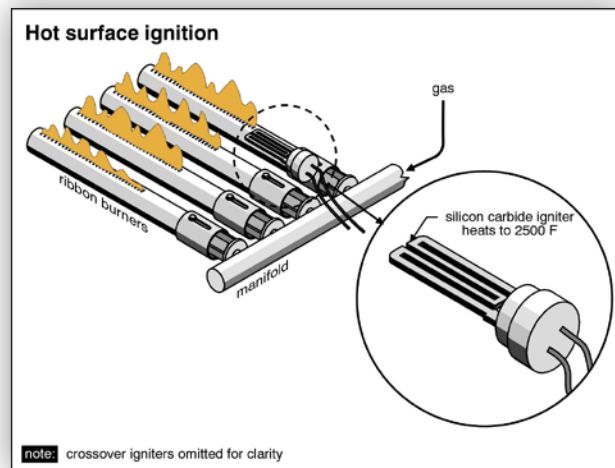
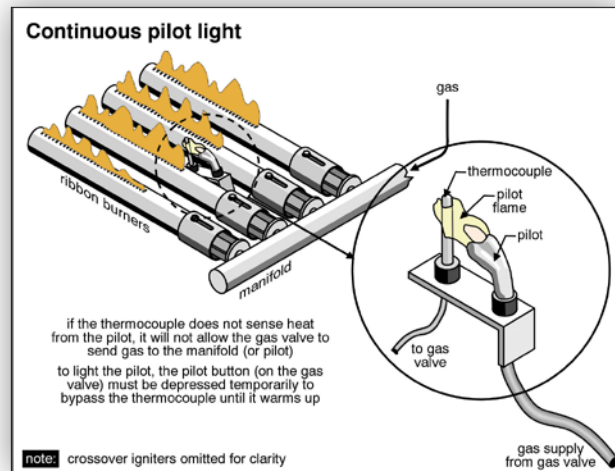

2.3 Oil

2.3.1 Oil Tanks and Piping: Fuel oil for heating systems is typically stored in a steel or fiberglass tank, which may be either inside or outside the building, above or below ground.

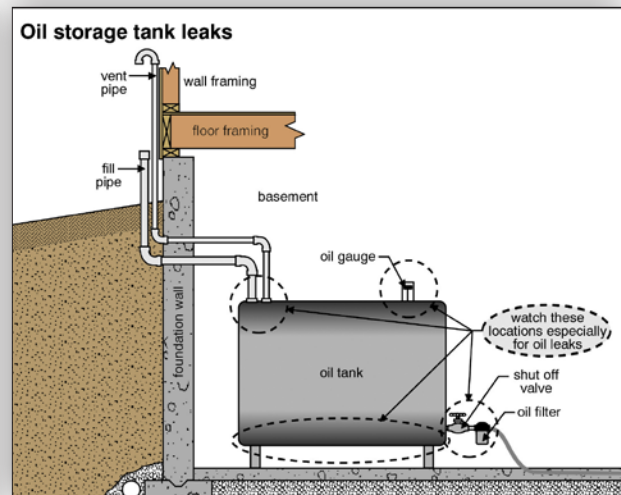
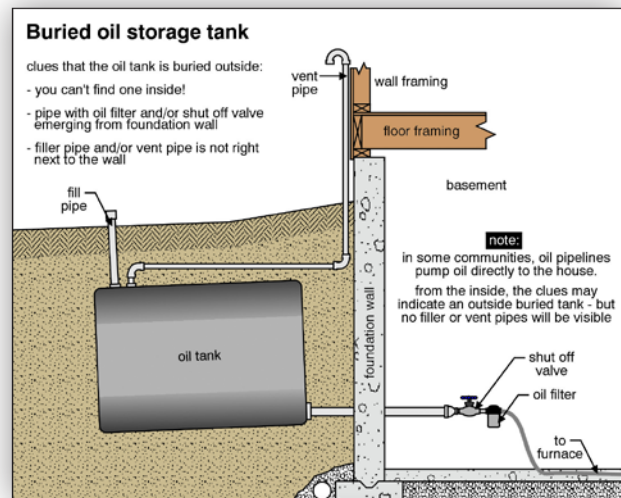
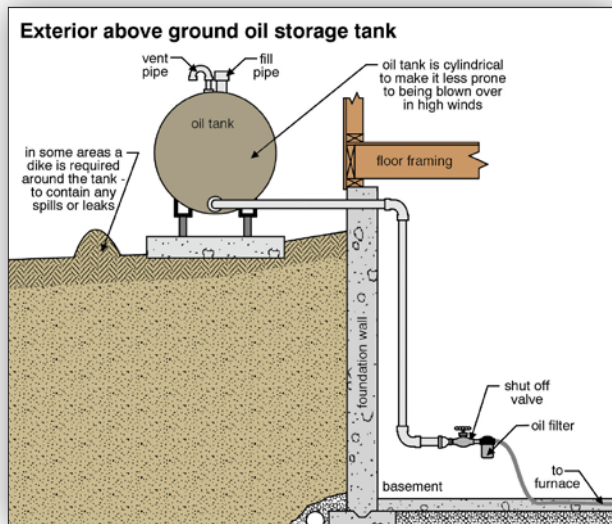

Common Problems with Oil Tanks

- LEAKS** Leaks can occur in the tank, filter and oil line leading to the burner. Leaking filters and lines can be easily repaired or replaced; however, a leaking tank is typically replaced.
- POOR LOCATION** For safety reasons, oil tanks should be kept away from sources of combustion such as oil burners. Outdoor tanks should not be subject to constant wetting from water running off the roof, and should be protected from mechanical damage by vehicles.
- WRONG TYPE** Some tanks are meant for use indoors, others are meant for use outdoors. An indoor tank installed outdoors may fail prematurely.
- CONDENSATION** Rusting occurs due to water in the tank (often from condensation). Water is heavier than oil and settles to the bottom of the tank. This is where most of the damage occurs. It is best to keep the tank full during the summer months to minimize condensation.

SUSPECT SUPPORT Oil tanks may fail because their legs rust and collapse due to moisture.

UNDERGROUND TANK? The presence of an underground tank cannot always be confirmed. A specialist should be consulted regarding the presence and condition of the tank. This is important because of the risk of soil and groundwater contamination from a leaking tank, whether in use or abandoned.

2.3.2 Oil Burners: Oil burners consist of a fan to force air into the combustion chamber, a pump to force oil into the combustion chamber, a nozzle to convert the oil to a fine mist, and an ignition system to ignite it.

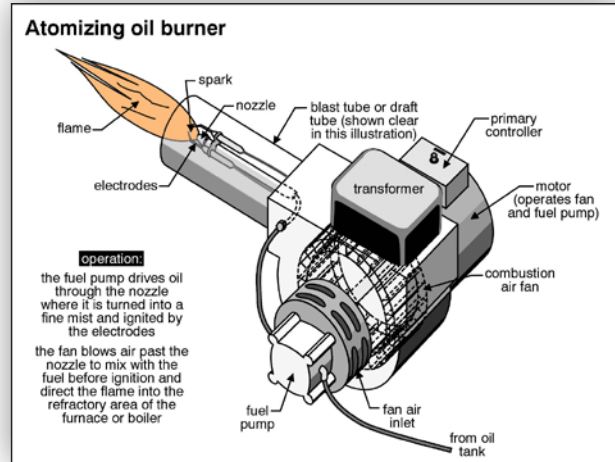

Common Problems with Oil Burners

POOR ADJUSTMENT Poorly adjusted burners result in increased heating costs. Burners starved for air are costly to operate and may generate dangerous carbon monoxide. Oil burners should be serviced annually. Old systems should have an annual efficiency test as part of regular servicing.

LEAK A leaking oil burner may be a safety risk and an environmental hazard.

DESCRIPTION 2.3.3 Combustion Chamber Refractory: Refractory is found in oil fired boilers and furnaces, which burn hotter than gas heating systems. It contains the flame in a controlled area. It may be a similar material to firebrick found in fireplaces and, in some cases, is made of firebrick. Its purpose is to protect the other heating system components from direct contact with the flame.

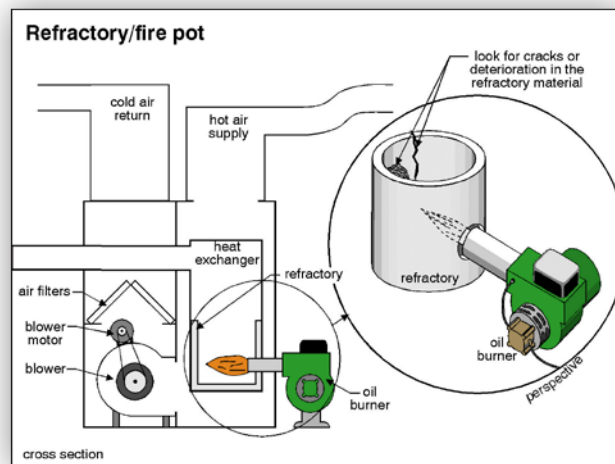

The Common Problem with Combustion Chamber Refractory

DETERIORATION Refractory deteriorates with time and exposure to flame, and requires repair or replacement from time to time. It is often not visible without dismantling the system or breaking a mortar seal. Deteriorated refractory can lead to overheating and the risk of fire.

DESCRIPTION **2.3.4 Primary Control:** The primary control prevents the burner from operating if it is not safe. The control may be mounted on the exhaust flue or on the burner. When installed on the flue, the device looks for heat in the exhaust pipe. If the oil burner is pumping oil into the burner area and the primary control senses no heat in the exhaust pipe, it concludes that the oil is not being ignited and it shuts off the pump. We don't want to accumulate a large pool of oil in the combustion chamber and then have it ignite violently later.

Newer oil burners use a cadmium sulfide 'eye' or photocell on the burner that verifies ignition by looking for light at the burner rather than heat.

Most primary controls have a reset button on them. It should be pressed only once if the furnace fails to ignite. Pushing the reset button several times could allow an unsafe accumulation of oil in the combustion chamber.

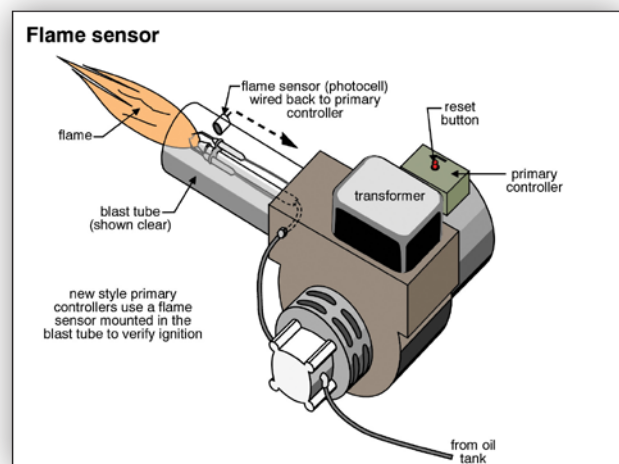
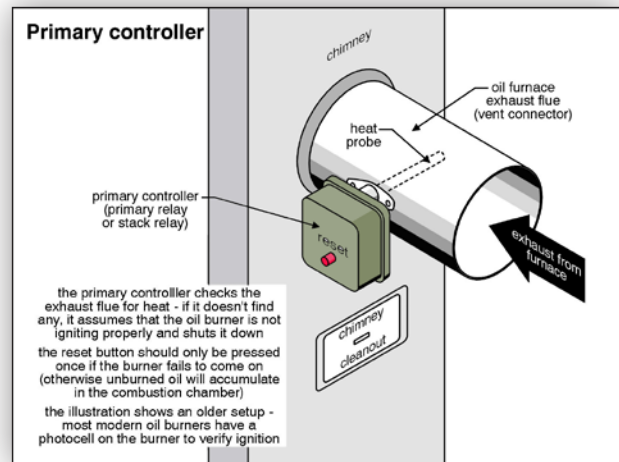

The Common Problem with Primary Controls

INOPERATIVE A heating system may be inoperative because of a defective primary control. It is beyond the scope of the professional home inspection to determine the cause of an inoperative heating system.

2.4 Combustion Air and Dilution (Draft) Air

DESCRIPTION All fuel-burning systems need air to mix with the fuel. If the burner is in an enclosed room or closet, ventilation should be provided. This is often done with louvers in the furnace room door. Natural draft appliances also require extra dilution or draft air to ensure the exhaust gases will be carried up the chimney. As a rough rule, 15 cubic feet of combustion air and 15 cubic feet of draft air are required to burn one cubic foot of natural gas in a conventional furnace.

NATURAL DRAFT APPLIANCES MORE SUSCEPTIBLE TO PROBLEMS Oil burners also need combustion air but have fewer problems, because the oil burner has a strong fan that draws air into the burner. Conventional gas furnaces rely on natural draft and are more susceptible to problems. Many newer gas furnaces have a fan that pulls air into the burner, reducing the need for draft air. These systems are less susceptible to draft problems than natural draft furnaces.

HIGH EFFICIENCY FURNACES Some high efficiency furnaces bring outside air for combustion directly into the burner through a closed pipe. This reduces heating costs because we are not wasting indoor air that we have heated to room temperature for combustion. Pressure sensors in the furnace verify air supply before the burner is allowed to fire.

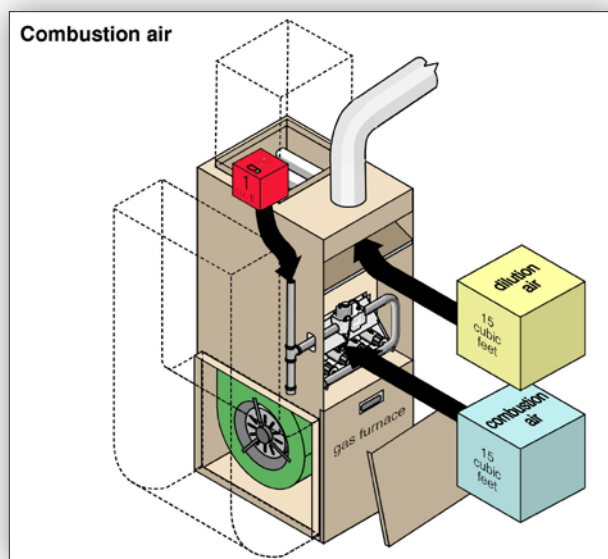

The Common Problem with Combustion Air

INADEQUATE COMBUSTION/ DILUTION AIR The most common problem is a lack of combustion and dilution air, often because the heating system is in an enclosed room or closet. There may also be a problem when combustion air is drawn from outdoors, if the inlet is obstructed. The heating system may not operate if there is a lack of combustion air. The system may operate inefficiently, and there may be a risk of combustion products spilling into the living space, creating a life safety issue.

2.5 Venting – Getting Rid of the Exhaust

DESCRIPTION 2.5.1 Draft Hood (Draft Divert-er): Conventional gas heating systems have a draft hood or draft diverter in the exhaust system. This hood allows room air to be drawn into the exhaust system to help the exhaust gases go up the chimney and out of the house. This draft or dilution air helps cool the exhaust gases as it mixes with them. It also ensures there will be enough draft to keep things moving up and out of the chimney.

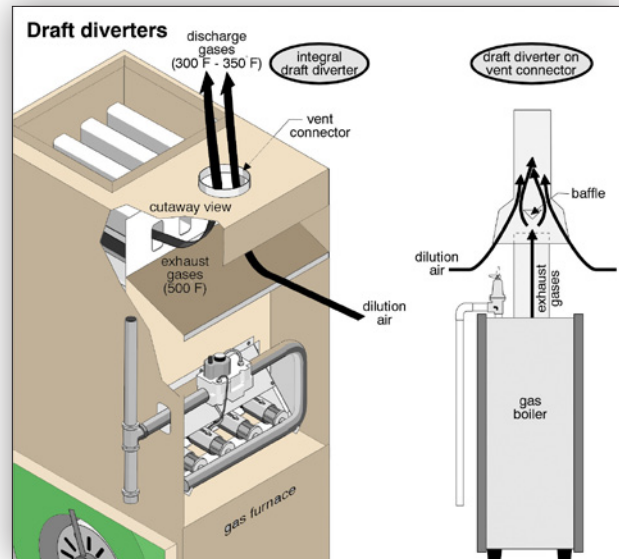

Common Problems with Draft Hoods/Diverters

OBSTRUCTED/NEGATIVE AIR PRESSURE IN HOME If the chimney is blocked or if the house air pressure is lower than the outdoor air pressure, exhaust gases may spill out of the draft hood, creating a dangerous situation for the occupants. This is often called backdrafting or spillage.

DESCRIPTION 2.5.2 Barometric Damper (Draft Regulator): Oil burners and some gas burners have a barometric damper (draft regulator) in the exhaust flue. This damper allows house air to be drawn into the exhaust flue to help exhaust gases go up the chimney. The barometric damper is safer than the draft hood, in that the damper will close if the pressure in the exhaust flue is higher than in the home. This prevents exhaust gases entering the living space.

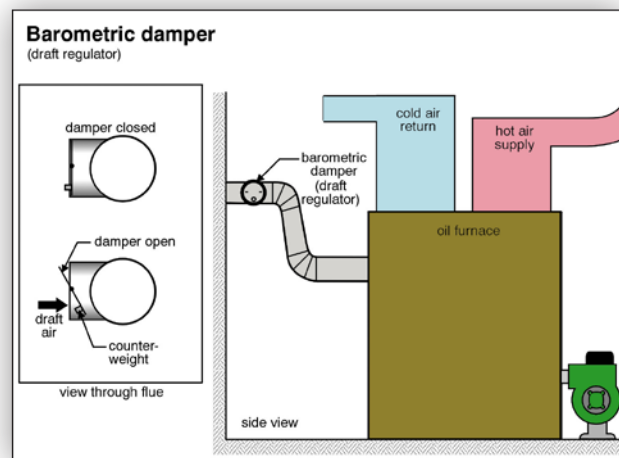

Common Problems with Barometric Dampers

RUST/ ADJUSTMENT Many primary controls have a damper that is in a harsh environment – the exhaust flue. It is common for dampers to be rusted, damaged or out of adjustment. The damper may be stuck and may not move at all. If the damper does not swing freely, service is required to ensure the heating system operates safely and efficiently.

DESCRIPTION **2.5.3 Vent Connector:** The vent connector carries the hot exhaust gases from the furnace or boiler to the chimney. It is typically a single-wall galvanized steel pipe, four inches to ten inches in diameter. Vent connectors for oil heating systems have to deal with higher temperatures than gas systems. Vent connectors for gas systems typically require a six-inch clearance from combustibles, and vent connectors for oil systems need nine inches or more.

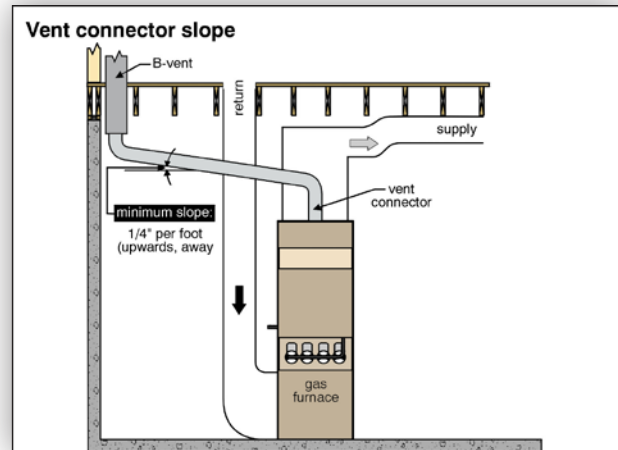

Modern high efficiency gas heating systems remove so much heat from the combustion products that the exhaust gases are cool enough to be carried in plastic pipes and discharged out through the side of the building, rather than up through a chimney.

Common Problems with Vent Connectors

POOR CONDITION AND LOCATION Problems include poor connections and corroded metal. Flues should not extend into the chimney far enough to obstruct the flow of gases out of the flue and up the chimney.

LENGTH Vent connectors that are too long may cool the exhaust gases, causing condensation and poor draft problems. Exhaust flues from oil furnaces for example, should be no more than ten feet in length.

SLOPE/ CONNECTIONS Vent connectors should slope up toward the chimney to allow exhaust gases to flow easily (at least one-quarter inch per foot). Individual sections of the vent connector must be well secured, typically with three screws. Vent pipes must be well supported to maintain a proper slope and to reduce stress on connections.

SIZE An undersized vent connector may restrict the flow of exhaust gases. An oversized vent connector may allow exhaust gases to linger and not move up and out the chimney.

- EXHAUST SPILLAGE – BACKDRAFTING** Conventional furnaces need air to maintain draft up the chimney, in excess of the air needed for combustion. Where this is not available, exhaust gases may not go up the chimney. Exhaust gases spilling from the exhaust flue, draft hood or burner area, may present a life threatening situation. This problem requires immediate action.
- CLEARANCE TO COMBUSTIBLES – VENT CONNECTOR** Exhaust gases can be 300°F - 700°F. A minimum of nine inches clearance should be provided for oil furnaces and special collars should be used where the exhaust flue (vent connector) passes through a combustible material. Gas furnace flues should be at least six inches from combustibles (Oil burns at higher temperatures than gas). There is a risk of fire where combustible clearances are not maintained.
- INAPPROPRIATE MATERIAL** Plastic venting is acceptable for some gas heating systems but not all. The venting material must be suitable for the application to ensure the heating system operates safely.

2.5.4 Chimney: Gas and oil heating systems require a chimney. Electric heating systems do not, since there are no products of combustion. Chimneys are typically masonry or metal. High efficiency systems and some mid-efficiency gas systems with relatively cool exhaust have plastic vent pipes rather than a chimney. There have been recalls on High Temperature Plastic Vents (HTPVs) for mid efficiency gas furnaces.

2.5.4.1 Masonry: Brick chimneys can be lined or unlined. An unlined chimney has brick or concrete block on the interior. While this is suitable for many oil furnaces, it is not suitable in most areas for gas furnaces or boilers, because condensing exhaust gases can damage the chimney. The liner can be metal, clay tile, or asbestos cement pipe. Where more than one appliance vents into a chimney, the smaller appliance should connect above the larger one.

SHARED CHIMNEYS In attached housing, it is common for two houses to have one chimney. Chimneys may have more than one flue. Each home may have one or two flues. When repairs to the masonry are required, the cost is often shared. Where this situation exists, the neighbor should be consulted prior to starting chimney work.

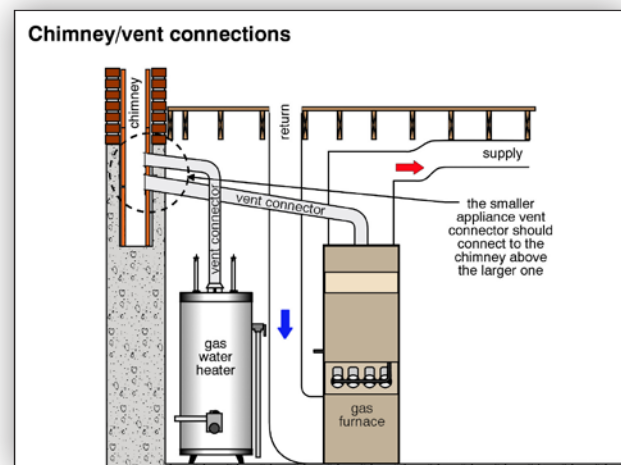

Common Problems with Masonry Chimneys

- DETERIORATION** Chimneys may deteriorate on the interior or exterior. Brick and mortar problems are common, especially near the top of chimneys or on the inside where condensation occurs as exhaust gases make their way up the chimney. The danger is exhaust gases getting back into the house. If the chimney is connected to a wood burning fireplace, there is also a risk of a house fire.
- LINER NEEDED** If mortar, sand or pieces of brick are found in the base of the chimney, a liner should be considered to prevent further chimney deterioration. A specialist should be consulted.
- POOR VENT CONNECTION** The vent connector should be well secured to the chimney to prevent leakage of exhaust gases in the home.
- SHARED FLUES** Two appliances sharing a single flue is not usually a good situation because exhaust from one appliance may come into the home through the vent for the other. A furnace and a fireplace, for example, should not share a flue. There are some circumstances where flues can be shared safely.
- DEBRIS IN CHIMNEY** Chimney flues without metal liners should have a clean-out door at the base of the chimney to remove debris. If debris accumulates in the bottom of the chimney, it could block the flue, causing exhaust gases to back up into the house.
- COMBUSTIBLE CLEARANCES/ FIREBLOCKING** Masonry chimneys should be kept at least two inches away from combustibles including wood framing. While there are exceptions, this is a good general rule. Fireblocking should be provided at each floor level so that a fire cannot quickly spread from floor to floor around the outside of the chimney. Non-combustible insulation is commonly used for fireblocking.

2.5.4.2 Metal: Metal chimneys for gas furnaces are typically Type B vents. Metal chimneys for oil furnaces are heavier Type L vents. Wood-burning appliances including fireplaces can also have metal chimneys. These are typically double- or triple-wall systems that see much higher temperatures than gas or oil vents.

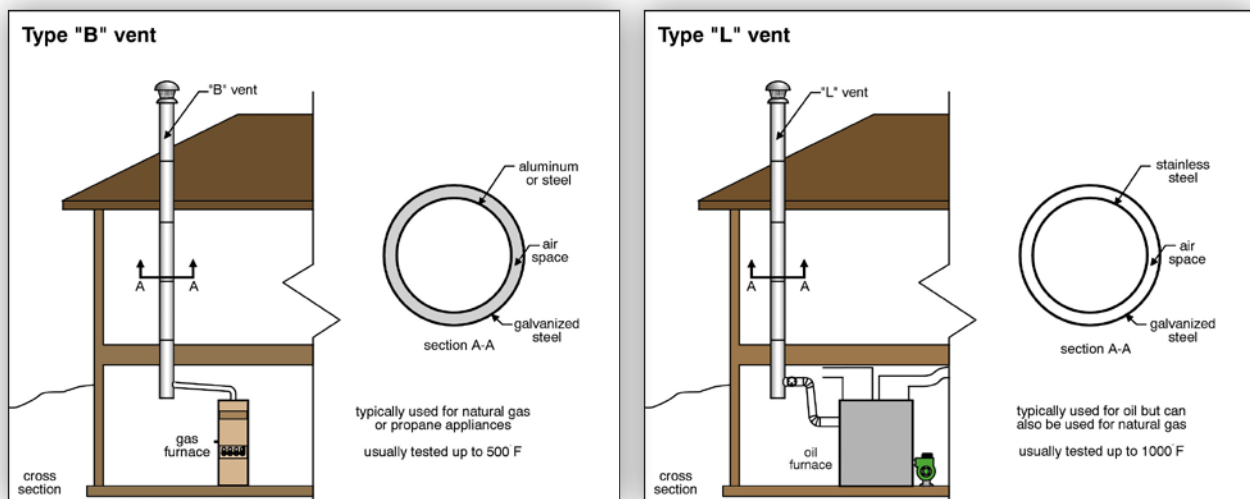

Common Problems with Metal Chimneys

- RUST/CORROSION** With time, the corrosive exhaust gases can deteriorate the interior of a metal chimney. Rust can also develop on the exterior of a metal chimney. Metal chimneys more than ten years old should be inspected regularly by a specialist.
- POOR CONNECTIONS/SUPPORT AND MISSING CAP** Other problems with metal chimneys include poor connection of sections, poor support for the chimney and missing rain caps. Products of combustion may find their way into the home.
- INADEQUATE CLEARANCE FROM COMBUSTIBLES** Type B and Type L vents require a one-inch clearance, and the special heavy metal chimneys used for wood-burning fireplaces typically require a two-inch clearance. Inadequate clearances may lead to overheating and fire.

3.0 Turning the Heat On and Off

All heating systems have controls to adjust the house temperature.

3.1 Thermostat

DESCRIPTION The function of a thermostat is to turn on the heating system when the temperature is lower than the setting, and shut the system off when the set temperature is reached.

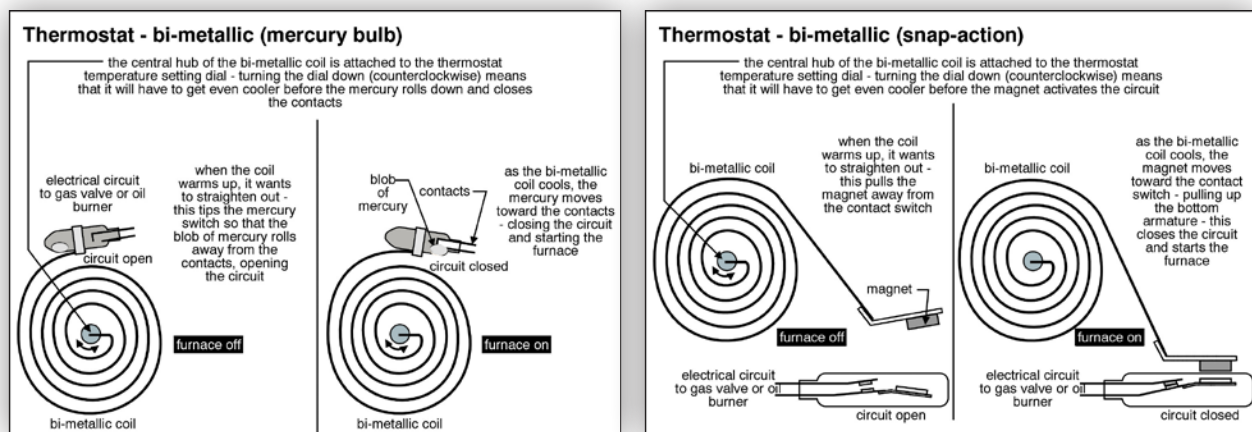

LOCATION The location of a thermostat is important for comfort. It should not be near a heat source such as a fireplace or a heating duct in the wall behind the thermostat. The thermostat should not be behind doors, on outside walls, in drafty areas or on walls that get direct sunlight. All of these can fool the thermostat into thinking the house is warmer or cooler than it actually is. Relocating a thermostat is not a difficult job.

PROGRAMMABLE OR SET-BACK THERMOSTATS Many modern thermostats are programmable and allow the temperature to be lowered when the occupants are away or sleeping. The maximum set-back should be less than ten degrees Fahrenheit, since cooler temperatures create higher relative humidity levels, which can result in condensation problems.

HEATING AND AIR CONDITIONING CONTROL Air-conditioned homes typically have one thermostat to control both heating and cooling.

BLOWER CONTROL Some furnace thermostats have a control for the blower (furnace fan) on forced-air systems. They either run the blower when the furnace operates or run the blower continuously. Continuous operation is often used with a good quality air filter to provide constant cleaning of the house air.

Common Problems with Thermostats

MALFUNCTIONS/ DAMAGE/ ANTICIPATOR PROBLEMS Thermostats can function improperly if they are dirty, not level, or improperly calibrated. They can also suffer mechanical damage. Most thermostats contain an anticipator – a device that prevents overshoot. If the heating system shuts down when the set temperature is reached, residual heat will overheat the home. The anticipator shuts the system off just before it reaches the set point, to avoid overheating. The anticipator must be calibrated to the specific furnace or boiler. If it is not, overshoot or short cycling may occur, resulting in an uncomfortable home.

POOR LOCATION The thermostat should not be placed where it may get a false reading of the room temperature. This will make the house uncomfortable and may increase heating costs.

4.0 Moving the Heat Through the House

We've been talking about how we can generate heat. Now let's talk about how we move the heat through the house. We'll look at furnaces, and then at boilers. We will also describe steam heating and electric systems.

Furnaces use ducts to move heated air. Boilers use radiators to move heated water. Hot water radiant systems move heat through concealed pipes. Electric systems can be furnaces, boilers, radiant systems within floors or ceilings, and space heating including electric base-board heaters.

5.0 Furnaces

DESCRIPTION Furnaces distribute their heat by warming the house air as it passes through the furnace. The furnace fan draws cool air in from the rooms through the return ducts. The air is warmed as it passes over a hot metal box called a heat exchanger. The warm air is pushed out to the rooms through the supply ducts. The house air can be thought of as moving in a loop, passing by the furnace every few minutes to be reheated.

Gas and oil furnaces have three major components: a heat exchanger, a burner, and a blower. Electric furnaces have a heating element rather than a burner to generate the heat.

Furnaces are typically in a cabinet. There are also operating and safety controls, and an air filter in the furnace. Gas and oil furnaces have a vent to get rid of the exhaust products. Some furnaces have accessories such as humidifiers or central air conditioning systems. Electronic air cleaners may replace conventional filters.

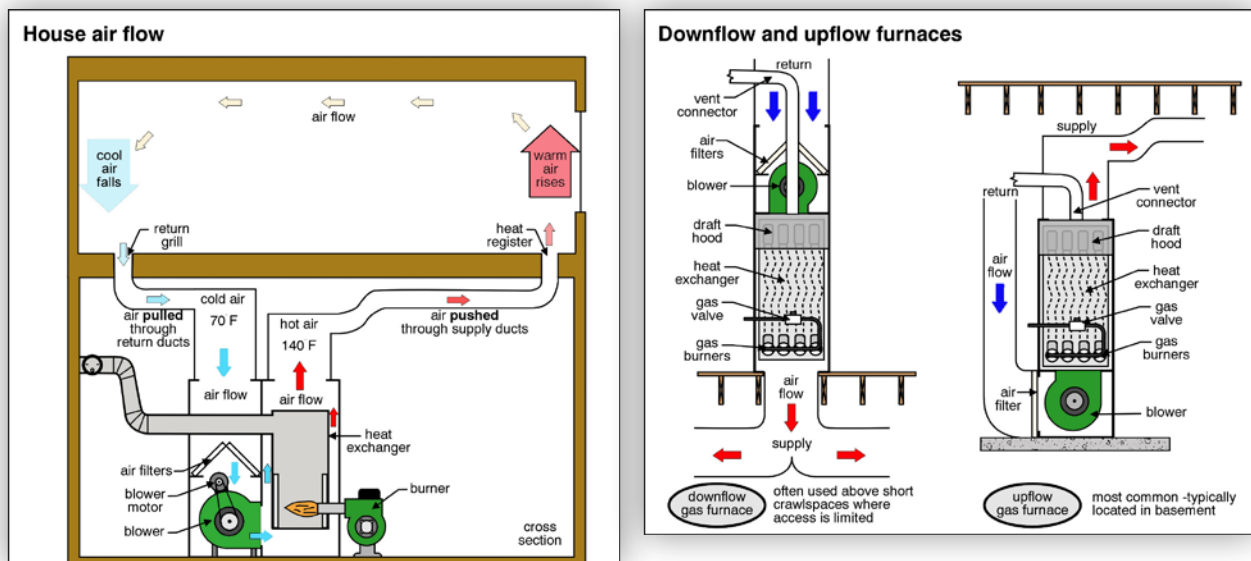

5.1 Electric Furnaces

DESCRIPTION Electric furnaces are similar in some ways to a hair dryer. Cool air is blown over a heating element. Since there is no combustion, there is no need for a burner, heat exchanger or vent system. These are replaced by electric elements sitting directly in the air stream. The blower simply forces house air across the heating elements, and the warmed air heads out through the supply ductwork.

Electric furnaces have multiple heating elements. A typical element is five kilowatts (5,000 Watts). Heating elements in electric systems are much like light bulbs. They burn out from time to time, and we can't predict when this will happen. Most electric furnaces have a sequencer to turn on the heating elements one by one, so that they don't create a large electrical surge.

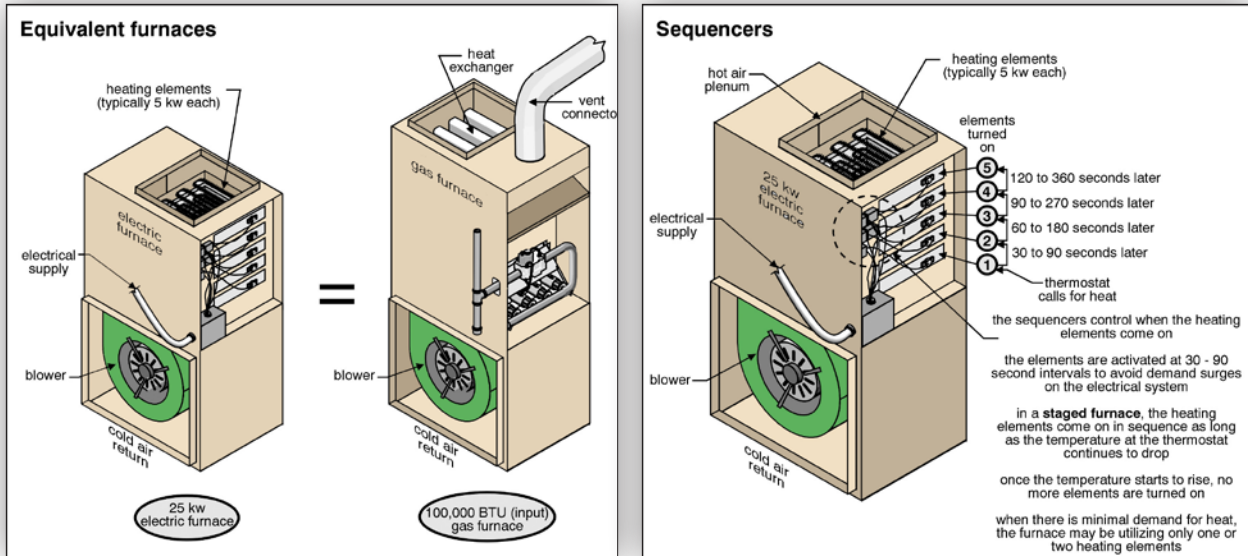

ELECTRIC PLENUM HEATER Some heating and air conditioning systems have an auxiliary electric plenum heater. Electric plenum heaters often do not work in conjunction with the furnace. The plenum heater will first try to satisfy the heating demands of the house. If it cannot keep up, the plenum heater shuts down and the furnace comes on.

Common Problems with Electric Furnaces and Heaters

INOPERATIVE The most common problem is a lack of heat due to a failed heating element, sequencer or control. In some cases the electric supply has been interrupted by a tripped breaker or blown fuse. The blower may also fail.

WIRING FAILURE The wires leading to heating elements and various controls sometimes overheat in electric furnaces. Any evidence of burned wires or components should be evaluated by a specialist.

5.2 Gas and Oil Burners

To review these burners, see Section 2 of this chapter.

5.3 Heat Exchanger

DESCRIPTION The heat exchanger is the most critical component of a gas or oil furnace. It separates the house air that is being heated from the burning fuel. The heat exchanger can be thought of as a metal box with fire on the inside and house air on the outside. House air picks up heat from the walls of the box. The burning fuel never comes in direct contact with the house air. This is an indirect-fired heating system.

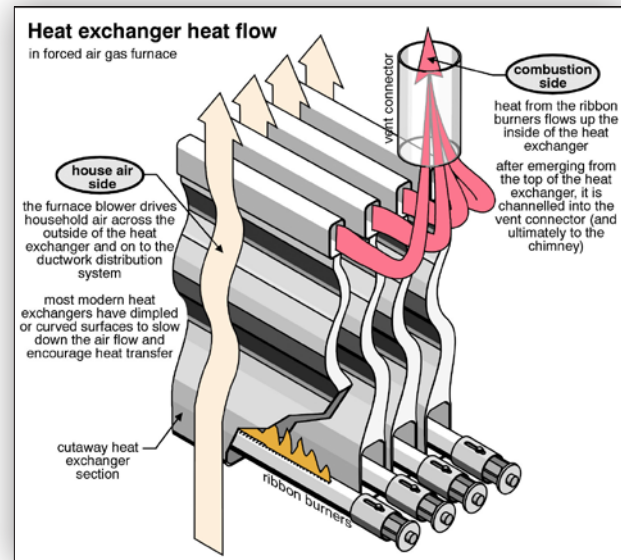

Common Problems with Heat Exchangers

- HOLE OR CRACK IN THE HEAT EXCHANGER** The exchanger is the heart of the furnace. It fails in one of two ways – it rusts through or it cracks. Either way, the products of combustion may escape through the heat exchanger and into the air supply to the house. This can be life-threatening, because the products of combustion may contain carbon monoxide, a poisonous gas. On some furnaces the heat exchanger can be replaced. Commonly, the entire furnace is replaced when the heat exchanger fails. A crack or hole in a heat exchanger is usually not visible, and typically will not be identified during a home inspection.
- LIFE EXPECTANCY** Heat exchangers in conventional furnaces have an average life expectancy of 18 to 25 years. The life expectancy of heat exchangers in high efficiency furnaces is somewhat less. We'll look at high efficiency furnaces shortly.
- LEAKING HUMIDIFIERS** Defective humidifiers, leaking condensate trays from air conditioning systems or moisture from damp basements can cause heat exchangers to rust prematurely.
- CORROSIVE ENVIRONMENTS** There are some environments where chemicals in the air are also corrosive to a heat exchanger. Swimming pool chemicals, paint strippers and the chemicals found in hair dressing salons for example, will rust a heat exchanger quickly. In a corrosive environment, a furnace with a specially protected heat exchanger is recommended.
- MANUFACTURING DEFECT** Some manufacturers have a reputation for heat exchangers with short life expectancies.

CLOGGED Some heating systems have very small heat exchanger passages. Over time and with incomplete combustion and condensation, these can become obstructed. This reduces the efficiency of the heating system and in some cases the heating system will shut down and there will be no heat. Flushing the heat exchanger is part of regular maintenance for some heating systems.

5.4 Blowers and Blower Motors

DESCRIPTION Furnaces have a blower to pull air into the furnace through the return ductwork, move the air across the furnace heat exchanger to warm it up, and push the heated air through the supply ductwork to heat the house.

The motor can be mounted within the blower to drive it directly. Some motors are external to the blower, driving the blower with a pair of pulleys and a belt. Belts and pulleys need regular maintenance and adjustment.

MULTI-SPEED BLOWERS AND HIGH EFFICIENCY MOTORS

Motors may have one single speed, or multiple speeds. One speed may be used to deliver warm air, and a lower speed used to continuously circulate air throughout the house. Some more expensive fan motors (ECM or Electronically Commutated Motors) are more efficient (use less electricity), but are more expensive than traditional (PSC or Permanent Split Capacitor) motors. ECM motors have the additional advantage of a larger range of operating speeds than conventional motors.

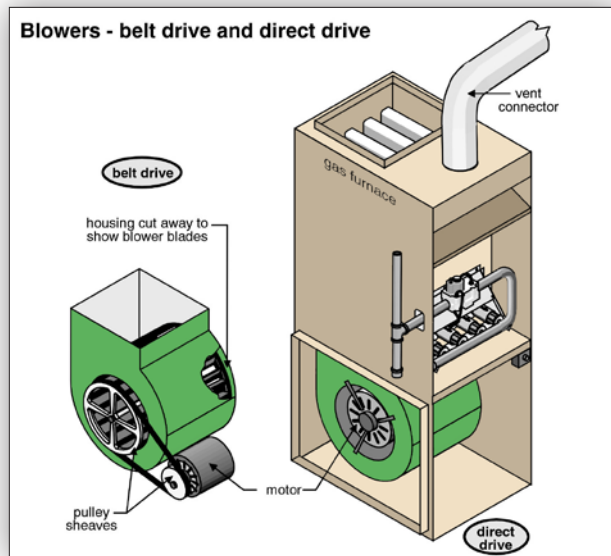

Common Problems with Blowers and Blower Motors

BURNED OUT MOTORS, WORN BEARINGS, DIRTY The most common problems are burned out motors and worn bearings. If furnace filters are dirty or missing, blowers get dirty and move less air, making the furnace work harder and the house less comfortable. Dirt can also cause the blower to get out of balance. This will cause excessive noise and vibration. Sometimes, vibration causes the entire blower unit to become loose. In other cases, the blower bearings may fail.

BELT-DRIVEN FAN ADJUSTMENT Belts may slip, reducing air flow and squealing. When the belt breaks, the fan stops and the furnace may overheat and shut down.

5.5 Operating and Safety Controls

DESCRIPTION **5.5.1 Fan/Limit Switch:** Many forced-air furnaces have a fan/limit switch. This switch has two functions. The first is an operating function. It tells the blower to come on when the furnace is warm enough to provide warm air at the registers.

The fan/limit switch does not shut off the fan when the burner is shut off. Since there is some residual heat in the heat exchanger, the fan keeps blowing until the fan/limit switch determines that the air coming out of the registers would feel cool.

The safety function of the fan/limit switch is to shut off the burner if the furnace overheats. These are typically set at 200°F. Older fan/limit switches are mechanical, and newer units are electronic. The illustration shows a mechanical fan/limit switch.

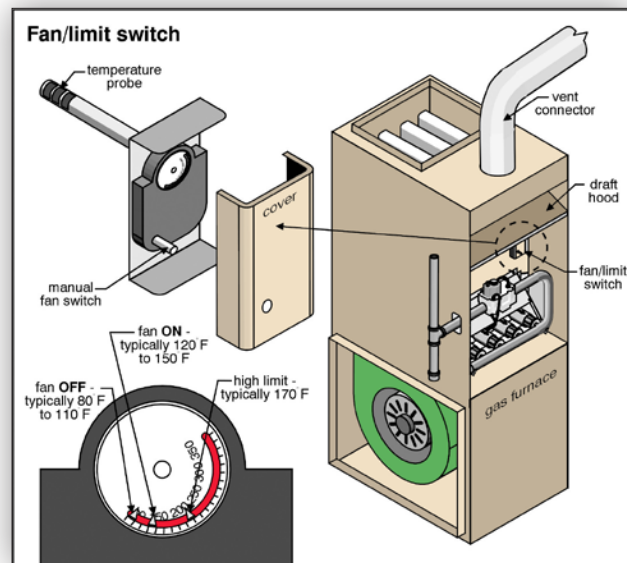

Common Problems with Fan/Limit Switches

SETTINGS Sometimes, fan/limit switches are out of adjustment, causing the furnace or the blower to short cycle (turn on and off at short intervals). Other causes of short-cycling include thermostat and heat exchanger problems.

If the limit setting is too high, or the switch is defective, the furnace may not shut off when it overheats. In some cases, this can cause a fire by igniting dust inside the ductwork or combustible materials nearby. The fan/limit switch should be checked during regular furnace servicing.

DESCRIPTION 5.5.2 Proving Ignition: Depending upon the type of furnace, there is also a safety device to verify ignition. It would be unsafe to allow unburned gas to accumulate in a furnace. A potentially explosive condition would exist. Older gas furnaces have a continuously burning pilot, which ignites the gas when the main gas valve opens. A thermocouple (heat sensor) verifies that the pilot is running. If the pilot goes out, the thermocouple will not allow the gas valve to open.

Some gas furnaces have an intermittent pilot that is ignited by a spark. Again, there is a flame sensor to ensure that the spark successfully ignited the pilot. If it does not, the gas valve will not open. A third option is hot surface ignition (also called electronic ignition), where there is no pilot. A flame sensor again makes sure that the system is operating safely.

Oil burners are typically spark-ignited. Heat or flame sensing devices (primary control) stop the burner from dumping fuel into the system if the burner is not firing.

Common Problems with Ignition Proving Systems

INOPERATIVE These systems are fail-safe devices. They may fail mechanically or electrically, but either way, they will not allow the burner to operate. The pilot valve may fail or the pilot orifice may become obstructed. It is also common for the thermocouple to fail, preventing the furnace from firing. The spark-ignited systems may have problems with the spark plug. The igniter may crack and fail to work on a hot surface ignition system. The implication of all of these is no heat for the home. It is beyond the scope of a professional home inspection to determine why a heating system is not working. A specialist should be engaged.

CONDENSATE LINE 5.5.3 Handling Condensate: On high efficiency heating systems, the products of combustion (exhaust gases) are cooled to the point where condensation forms. This condensate (water) must be collected and drained away. Sometimes, the drain lines are plugged or poorly installed.

Some municipalities require the condensate to be neutralized before it goes into the drains. It is somewhat acidic and may deteriorate city piping. Neutralizing kits are available through furnace manufacturers.

CONDENSATE PUMP If a condensate line cannot flow by gravity to a drain, a condensate pump is installed. The pumps are relatively inexpensive but can be a high maintenance item.

Common Problems with Condensate Systems

**LEAK/CLOGGED/
FAILED PUMP/
POOR DISCHARGE
POINT** The most common problems are leaks that may be the result of clogged or disconnected condensate lines. Failed condensate pumps can also result in leaks. Depending on where the water goes, there may be damage to the furnace or surrounding area. Neutralizing salt baths may also be clogged, resulting in backup and leakage.

DESCRIPTION 5.5.4 Back Draft Sensor – Spillage Switch: Some furnaces have a spillage switch to detect exhaust products escaping out of the front of the burner. This safety device shuts off the burner if spillage (back drafting) is detected.

Common Problems with the Spillage Switch

INOPERATIVE/ The spillage switch may be inoperative, damaged, or out of position as the result of impact.
DAMAGE/ If the spillage switch does not work, the furnace will not operate and the house will have
DISPLACED no heat.

5.5.5 Air Proving Switch (Differential Switch): Furnaces with induced draft fans have a sensor that makes sure air is moving through the intake, combustion and venting system before the burner is allowed to fire. These sense the pressure differential across the fan, making sure there is good airflow.

Common Problems with the Air Proving Switch

INOPERATIVE/ The switch may be inoperative or damaged. If the heating system does not work, the
DAMAGE/ switch may be doing its job, because it has detected a problem with the airflow, and shut
DISPLACED the system down.

5.6 Filters

Furnaces have a filter to clean the air before it enters the furnace. Filters protect the furnace, keeping it clean, and help maintain good air quality throughout the house.

AIR FILTER There are several types of air filters that clean the return air before it goes into the furnace and out through the registers. This cleans the house air and helps keep the furnace clean. Conventional air filters sit in the return air plenum, just upstream of the blower. It is not unusual to find filters installed backwards or missing.

ELECTRONIC Electronic air filters (also called
AIR FILTER electronic air cleaners) clean the air better than conventional mechanical filters. Because they can help to remove pollen and cigarette smoke particles, these are good for people with allergies. The units have a preliminary mechanical filter to remove larger airborne debris. The smaller particles that get through the filter are electrically charged and then collected on plates of opposite polarity. When one hears an intermittent sparking or crackling noise, the unit is functioning properly.

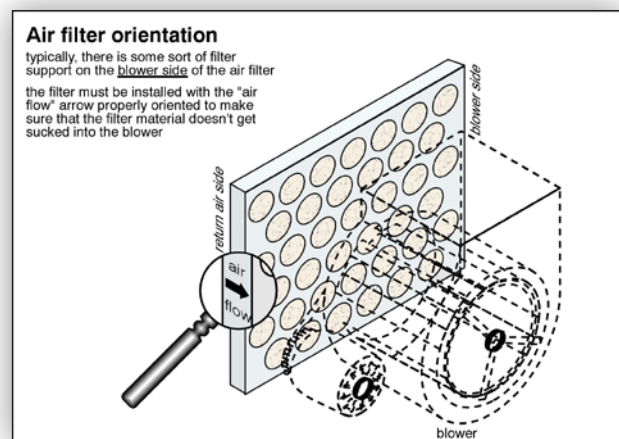

Activated charcoal filters to help absorb odors are often included with electronic air filters. These are usually downstream of the electronic filter collector plates.

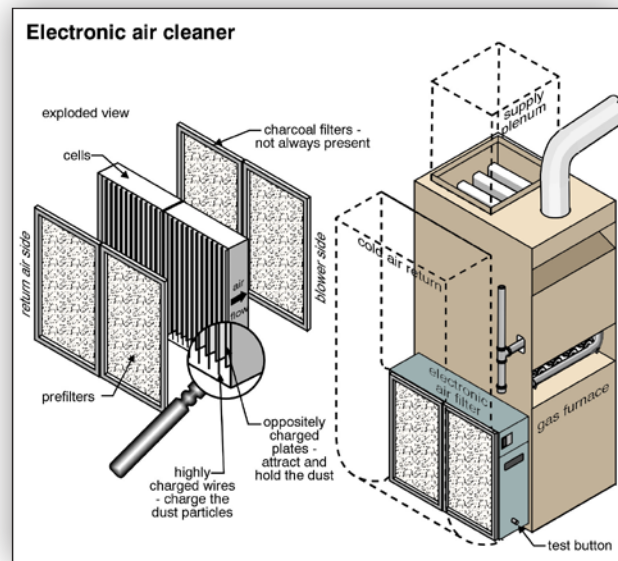

Common Problems with Air Filters

- DIRTY** Some are cleanable while others are disposable. Regardless of the type, they should be checked monthly. Clean filters improve the comfort of the home, help to reduce heating costs and protect the heating and cooling equipment.
- IMPROPER ORIENTATION** When the removable components are put back in the ductwork, care must be taken to ensure that they are installed in the right orientation. An arrow indicating airflow should point toward the blower.
- MISSING** It is not unusual for the filter to be missing altogether. Dirty filters are sometimes removed with the deferred intention of buying a new filter.
- INOPERATIVE ELECTRONIC AIR CLEANER** From a visual inspection it is not always possible to determine whether an electronic air filter is working properly. In some cases, the power supply has been interrupted and simply needs to be reactivated. The implication is poor air circulation or a dirty furnace.

5.7 Humidifiers

- DESCRIPTION** Many furnaces have a humidifier to add moisture to the house air through evaporation, combating the dry winter air in homes. There are several types of humidifiers.

HUMIDIFIER TYPES Drum-type humidifiers are common. They are simple and fairly inexpensive. They should be mounted on the return air ductwork with a bypass duct to the supply plenum. They should not be directly above the heat exchanger. We don't want water rusting the furnace heat exchanger when the humidifier leaks.

TRICKLE HUMIDIFIERS Trickle (cascade) type humidifiers that allow water to fall over a special pad are usually high-quality units. The water that is not evaporated is collected and flows to a drain.

ATOMIZING AND STEAM HUMIDIFIERS Atomizing humidifiers and steam generating units are high quality and are rarely seen residentially. Due to their design, the inner workings cannot be inspected during a visual examination.

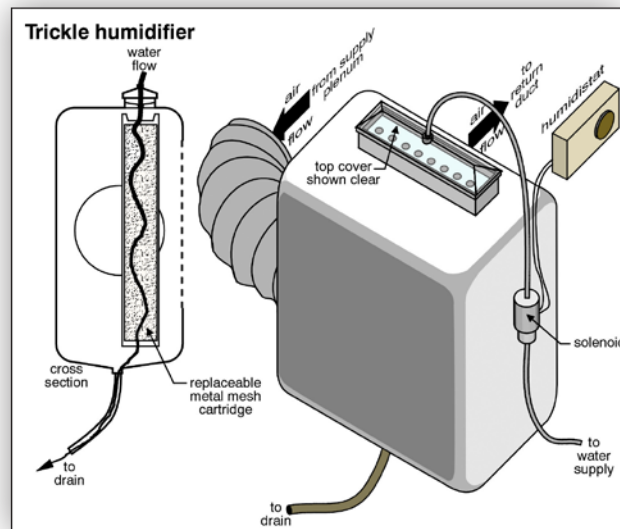
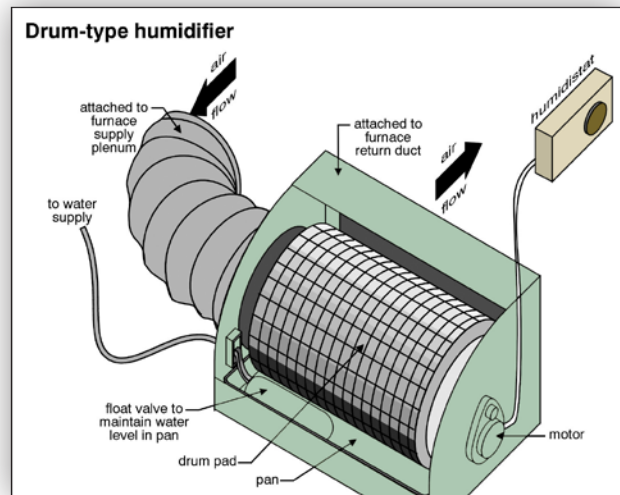

Common Problems with Humidifiers

TOO MUCH HUMIDITY If too much humidity is added, condensation forms on windows and on other relatively cool house surfaces. Condensation can also form inside wall and ceiling cavities, causing rot and mold.

HUMIDITY LEVELS Unfortunately, the ideal humidity level for the house is not the same as the ideal humidity level for people. People like higher levels than are desirable from the house's perspective. To prevent condensation and mold, the following should be observed:

Outside House Temperature	Humidity Level
20 degrees F.	15%
-20 to -10 degrees F.	20%
-10 to 0 degrees F.	25%
0 to +10 degrees F.	35%
+10 and above degrees F.	40%
Summer months	Off

FAULTY HUMIDISTAT, LEAKS, SEIZING Drum humidifiers have several common problems. The control or humidistat may be defective or poorly adjusted. The water reservoir may overflow due to poor adjustment, or float or valve problems. This may rust the furnace. The tray sometimes overflows because mineral deposits foul the automatic water supply valve, causing it to stay open even when the tray is full. Leaks at the water supply line or valve are also common.

The drum pad itself gets clogged with mineral deposits, seizing the drum, which in turn burns out the motor. Replacement parts for these humidifiers are not expensive.

DUCT DAMPER – WRONG POSITION A humidifier duct damper should be provided if there is an air conditioner connected to the furnace. This damper should be kept closed during the cooling season to prevent air conditioner coil ice-up due to short-circuiting of the airflow.

5.8 Ducts, Registers and Grilles

DESCRIPTION Furnaces have two sets of ductwork: one to supply the air to the rooms in the house, and a second to return air to the furnace. Every room in the house should have at least one supply air register. Ideally, each room would have a return air register; however, most houses have fewer return air grilles. Return air systems are often centrally located in hallways and at the bottom of stairwells.

Common Problems with Ducts, Registers and Grilles

- MISSING/INEFFECTIVE SUPPLY REGISTERS** Some rooms have no heat. Some registers are poorly located. Supply registers should be located near exterior walls, below windows. However, it is often not cost-effective to relocate existing registers. Some registers provide very little heat. The ductwork may be obstructed, damaged or disconnected. The result is an uncomfortably cool room.
- MISSING/TOO FEW/UNDERSIZED RETURN POINTS** Ideally, every room with a supply register should have a return air grille; however, this is almost never the case. In many older homes there are one or two centrally located return air grilles. Rooms with supply air registers and no return air grilles should have doors with a one-inch gap at the bottom to allow air from the room to get to the return air grille when the doors are closed. The total supply register area should equal the total area of the return air grilles. It is common in older homes to find inadequate return air. This leads to uncomfortable rooms and higher heating costs.
- MISSING/INOPERATIVE GRILLES** Supply registers and return grilles are often missing or painted shut. They are easily replaced.
- DIRTY/BROKEN** Return air ductwork often accumulates debris. Older return grilles in floors are often broken and may not safely support people or furniture.
- POOR LOCATION** Ideally, the supply registers should be located on an outside wall below a window (the coolest part of the room), and the return register should be located on an opposite wall (the warmest part of the room). In some houses, return air registers were provided near the supply air registers.

Some of these systems short-circuit in that the warm supply air is simply drawn back into the return air register, with little heat going to the room itself. Sometimes, simply blocking off the return air register will improve heating in a room considerably.

Some homes have supply registers near the ceiling. This is a less than ideal arrangement since warm air wants to rise, and all the heat will be at the ceiling. This is not usually cost-effective to change.

POOR LOCATION IN BASEMENT Supply registers in basements are often located in the ceiling, which is not ideal. Many people install supplementary electric baseboard heaters rather than relocate the registers.

UNSAFE LOCATION – GARAGE Supply air registers or return air grilles should not be provided in garages, since automobile fumes may be drawn into the house air.

OBSTRUCTED The house will be uncomfortable and heating costs will be higher if the air flow is obstructed. Carpeting and furniture should be kept clear of air flow paths. Ductwork may also be disconnected or incomplete, although this is difficult to determine visually.

HEATING DUCTS IN CONCRETE Slab-on-grade houses with forced-air heat often have heating ducts embedded in the concrete foundations and slab. Sometimes the ducts are partially collapsed during the concrete pouring process. Moisture in and around the slab can flood the ducts and rust the metal duct walls. The water standing in the ducts becomes a health hazard. Rusted duct walls can come loose and collapse. Any of these will restrict at least some air flow through the system. Ductwork in poured slabs and foundations is, of course, difficult to inspect and repair.

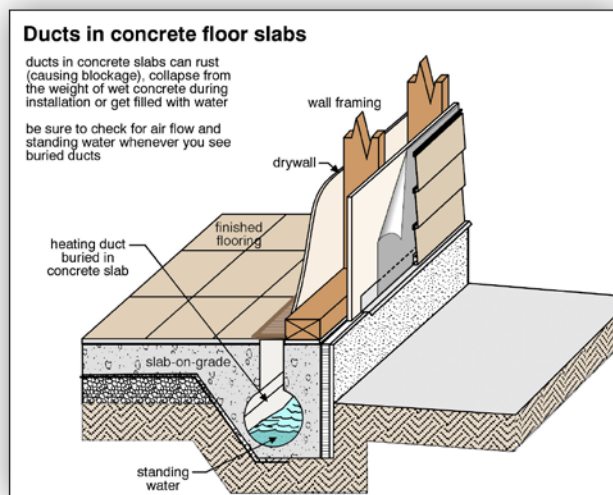

OTHER DUCT PROBLEMS Common problems with supply ducts and registers are disconnected or obstructed ducts, dirty ducts, ducts sized adequately for heating but inadequate for air conditioning, ducts sized for conventional furnaces, but inadequately sized for high efficiency systems, and unbalanced ductwork (too much air coming through one register and not enough air coming through another).

INOPERATIVE ZONE DAMPERS Some sophisticated warm-air heating systems are zoned. Thermostats in various areas of the house control dampers which open and close, directing air to the areas where heat is needed.

Motorized dampers in residential installations are often neglected and inoperative. The problems may be in the controls or the dampers themselves. In many systems, they are abandoned or removed.

5.9 Furnace Efficiencies

Both furnaces and boilers are classified by their efficiency.

5.9.1 Conventional Efficiency Systems: Until the mid-1970s, all systems were of similar (conventional) design and efficiency. Almost all had an operating (steady state) efficiency of approximately 80%. When the system was operating, 80% of the heat produced from burning the fuel went into the house. The other 20% went up the chimney. The systems are not 80% efficient over the entire heating season.

Since a furnace has to provide enough heat during the coldest day of the year, it is oversized every other day of the year. Consequently, systems do not run continuously during the winter.

OFF-CYCLE LOSSES When a conventional furnace is not operating, warm house air is escaping up the chimney. Even when the system is operating, a good deal of warm air is lost up the chimney, just maintaining adequate draft for the exhaust gases. On gas-fired systems, some fuel is wasted keeping the pilot on. Also, when a boiler or furnace is starting up or cooling down, it is not operating at full efficiency. If you combine the off-cycle losses with the start-up and cool-down losses, and add in the 20% losses during

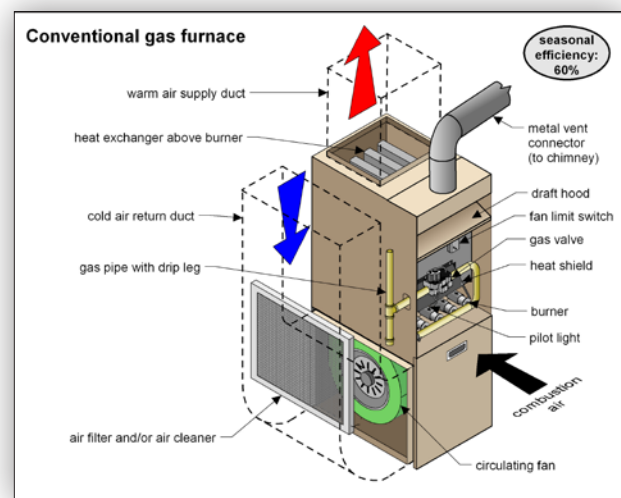

normal operation, the average seasonal efficiency of a conventional boiler or furnace is about 55% to 65%. That means 35% to 45% of the heat from the fuel is lost. With the advent of more efficient furnaces and boilers, this system became known as a conventional system. Conventional systems were phased out in the early 1990s.

DESCRIPTION 5.9.2 Mid-efficiency Systems: Most mid-efficiency furnaces are conventional units (although some have a secondary heat exchanger) with modifications to reduce off-cycle losses. The enhancement is often an induced draft fan in the exhaust, which only operates when the burner is on. Alternatively, a motorized vent damper may be used in the exhaust to prevent heat from escaping up the chimney when the system is shut down. Both of these strategies prevent heat loss to the outdoors when the system is idle.

Continuous pilots on gas systems are replaced with intermittent pilots. This avoids wasting fuel when the systems are not working. These improvements combine to almost eliminate the 20% off-cycle losses.

Mid-efficiency systems are not much more efficient when operating than conventional systems. However, their seasonal efficiency is much higher – typically 80%. This is a 20% improvement over conventional systems. We are only losing 20% of the heat from the fuel. Mid-efficiency systems are being replaced with high efficiency systems in the first part of the 21st century.

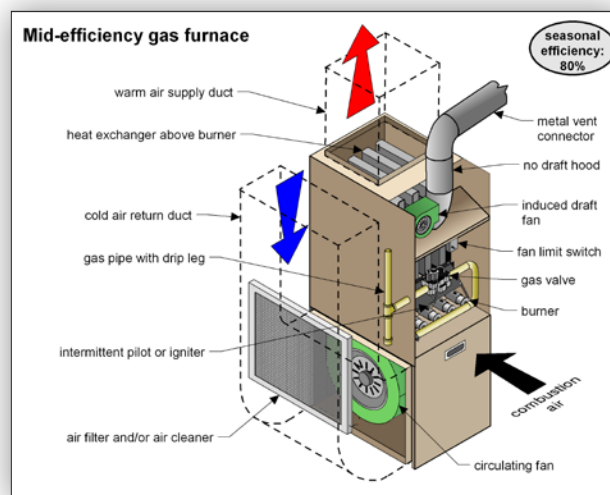

CONDENSING SYSTEMS **5.9.3 High Efficiency Systems:** High efficiency furnaces go a step further. They are also known as condensing furnaces because the exhaust gases are so cool they condense water. (One of the main products of combustion of burning natural gas is water.) These furnaces can withstand the slightly corrosive condensate and have a drainage system to collect it and carry it away.

While a conventional furnace has a single heat exchanger, high efficiency units may have two or three heat exchangers. High efficiency systems keep the hot exhaust gases in contact with the heat exchanger longer so that more heat is transferred to the house air or water.

High efficiency systems also limit the off-cycle losses, just like mid-efficiency systems. They have a seasonal efficiency in the 90% range, with some over 95%.

Since there are more components in a high efficiency system, there is more to go wrong and repair and maintenance costs are typically higher than a conventional furnace. At the very least, annual servicing is required. Many believe their life expectancy is also shorter.

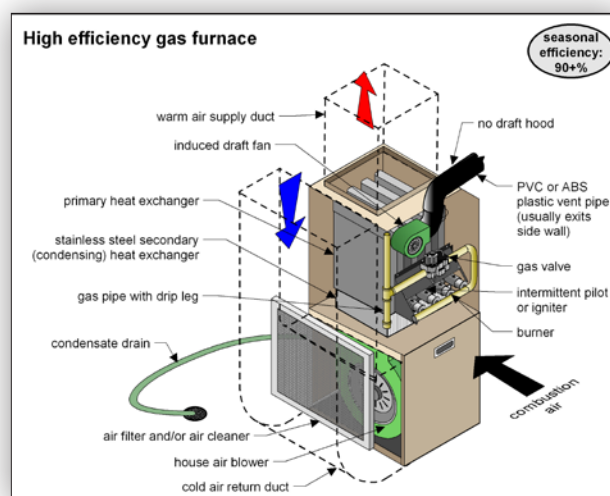

5.10 Combination Heating Systems (Integrated Mechanical Systems)

DESCRIPTION Combination heating systems use the domestic water heater to heat the house. The hot water in the tank can either flow to the plumbing system or to a fan coil unit to heat the house. The fan blows house air across the coil filled with hot water, picking up heat. The warm air is distributed to the house through ductwork. Water from a boiler can heat the home (through radiators or radiant floor heating, for example), and can also be used to heat the domestic hot water in a tank. These are often called indirect systems.

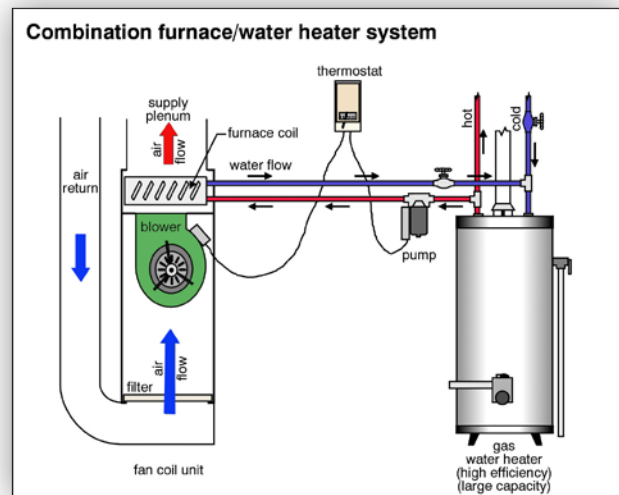

Common Problems with Combination Heating Systems

INADEQUATE HEAT Combination forced air systems tend to have modest capacity. Some systems have proved to be undersized for heating a home.

TEMPERING VALVE (MIXING VALVE) NEEDED As a result of inadequate heat problems, some homeowners turn up their domestic water temperature to as high as 170°F. This may result in scalding at plumbing fixtures. It may also result in pressure relief valves leaking on hot water tanks. If the units are to be operated at such high temperatures, mixing (tempering) valves to cool the domestic hot water are required. These valves mix cold water with the hot to lower the temperature.

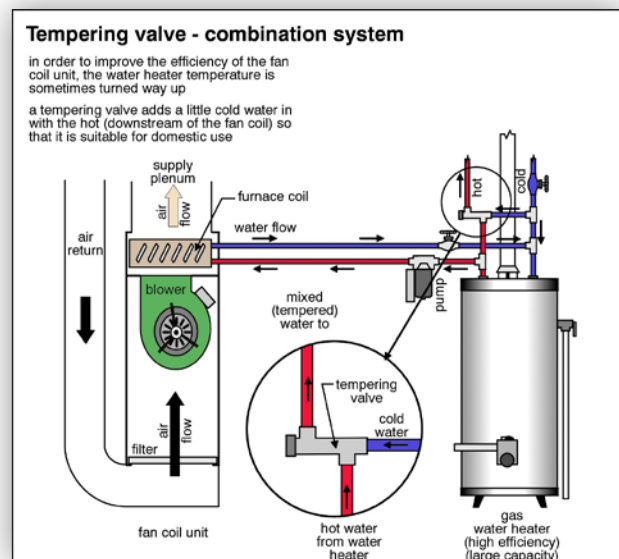

Some jurisdictions insist that the systems be designed so that the water temperature can be no more than 140°F and the design water temperature of the air handler is 130°F. This means that more airflow is needed to heat the house. The ductwork in many houses is not designed to handle these high volumes of air. This may make these systems a ques-

tionable solution for existing houses. Also, these systems appear to be more practical in climates where the heating demand is relatively small compared to the domestic hot water demand.

NEW TECHNOLOGY – SUSPECT These systems have not been around for several decades, but early experience has shown some reliability problems. We have seen some early failures of water heaters that are working much harder than they used to.

Pumps and tempering valves add some complexity. Controls can be an issue. Other problems include leaking or clogged coils. Failures result in no heat for the house.

5.11 Furnace Life Expectancy

- Life expectancies depend on many things, but there are some averages.
- Conventional and mid-efficiency furnaces – 18 to 25 years
- High efficiency furnaces – 15 to 20 years
- Combination heating systems – 5 to 10 years

6.0 Hot Water Boilers (also called Hydronic Heating)

DESCRIPTION Boilers heat the home by moving hot water through pipe loops. Heat is distributed at radiators, convectors or baseboards.

Hot water heating systems are called boilers, but they do not actually boil the water; they only heat it to a maximum of roughly 180°F. Steam heating systems, discussed in the next section, actually do boil the water.

A boiler consists of a burner, a heat exchanger and typically a pump. The burner generates heat within a combustion chamber. The heat exchanger allows the heat from the flame to heat the water that circulates through the house.

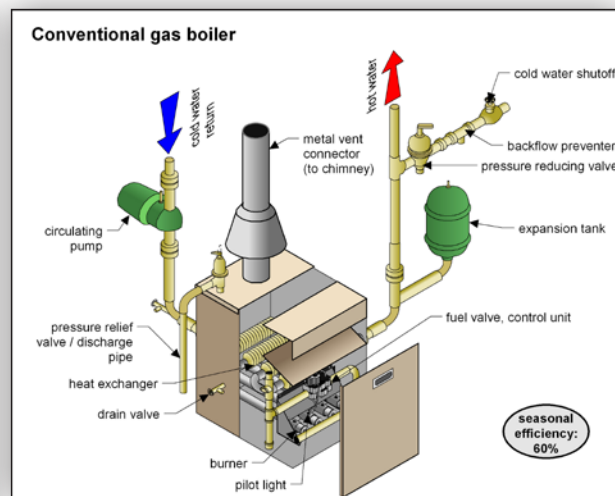
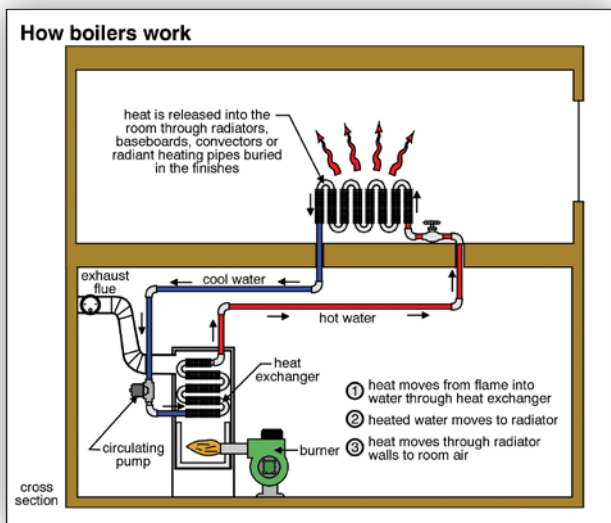

6.1 Electric Boilers

DESCRIPTION Electric boilers have electric heating elements rather than a heat exchanger. They work much like an electric water heater or a kettle, although they don't actually boil the water.

6.2 Gas and Oil Burners

We have discussed gas and oil burners in previous sections. We won't repeat those discussions here.

6.3 Heat Exchanger

DESCRIPTION With the exception of electric systems, all boilers have two major components: a heat exchanger and a burner. The heat exchanger, which is the heart of the boiler, has products of combustion on one side and the water to be heated on the other. The flame heats the metal heat exchanger, which in turn heats the water. Heat exchangers are made of cast iron, steel or copper.

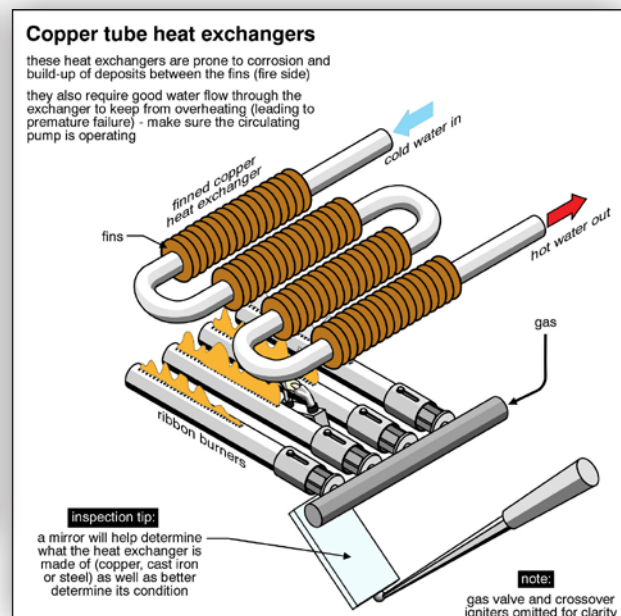
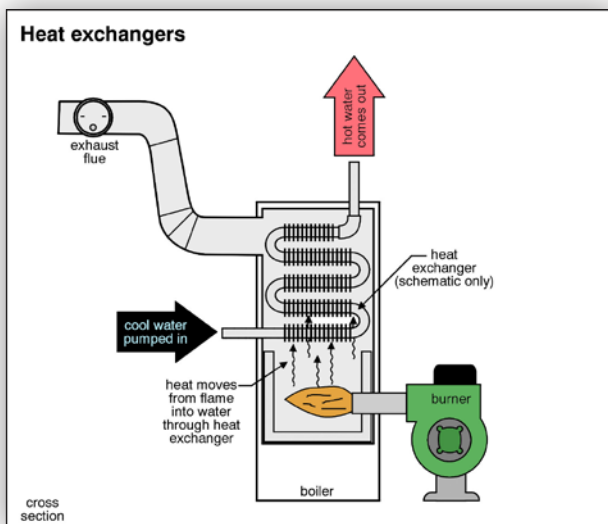
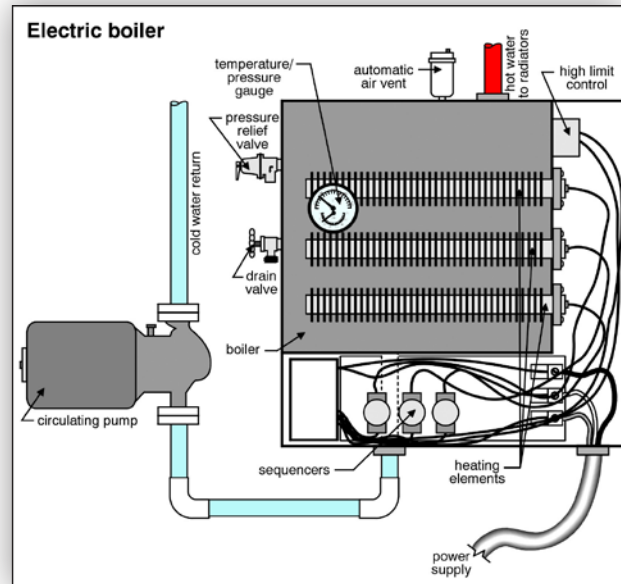

Common Problems with Heat Exchangers

- RUST/ CRACKS/HOLES** When a heat exchanger fails, it rusts through or cracks and water leaks into the combustion chamber and/or out of the boiler. The boiler usually shuts down and there is no heat for the home. The boiler is typically replaced when the heat exchanger fails.
- OBSTRUCTED** Corrosion on the fire side of the boiler can lead to clogging, which restricts the flow of exhaust products out of the house. This can be a dangerous situation with products of combustion getting into the home through the draft hood.

6.4 Pump

DESCRIPTION Older systems relied on gravity and convection to move water through the house but most systems now have a circulating pump. The pump may run continuously, or intermittently when the water in the boiler is above a certain temperature. Others operate whenever the boiler is operating.

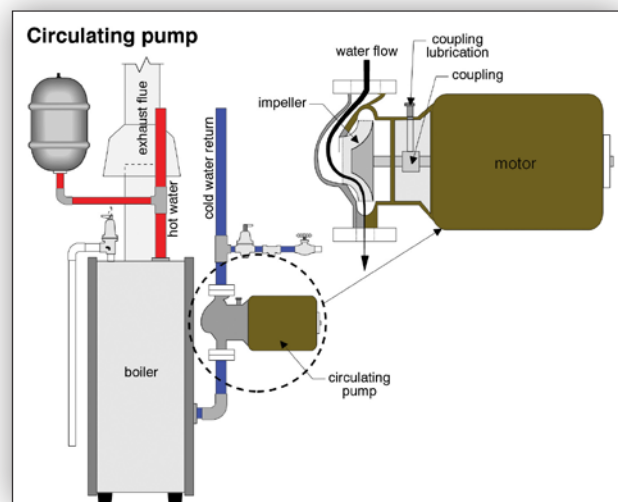

Common Problems with Circulating Pumps

- LEAK/ INOPERATIVE/ NOISY/HOT** The most common problems associated with circulating pumps are leakage and inoperative pumps caused by worn pump bearings, burned out pump motors and defective temperature sensors. Pumps that are about to fail may be noisy or hot to the touch.

In some cases the heating system will not operate if the pump fails. In other cases the heating system may continue to operate somewhat inefficiently.

6.5 Expansion Tank

CLOSED SYSTEMS Modern boilers are closed systems. The water in the system is under pressure. As the boiler heats up, the water expands and begins to fill an expansion tank, compressing the air in the tank. The air provides a cushion that prevents excessive pressure build-up. This expansion tank is usually near the boiler.

The air in an expansion tank eventually gets absorbed into the water, and expansion tanks have to be drained when they become waterlogged.

Some expansion tanks have a diaphragm or bladder that separates the water and the air. The air is never absorbed into the water and unless the diaphragm fails; the tank will theoretically never become waterlogged, reducing maintenance.

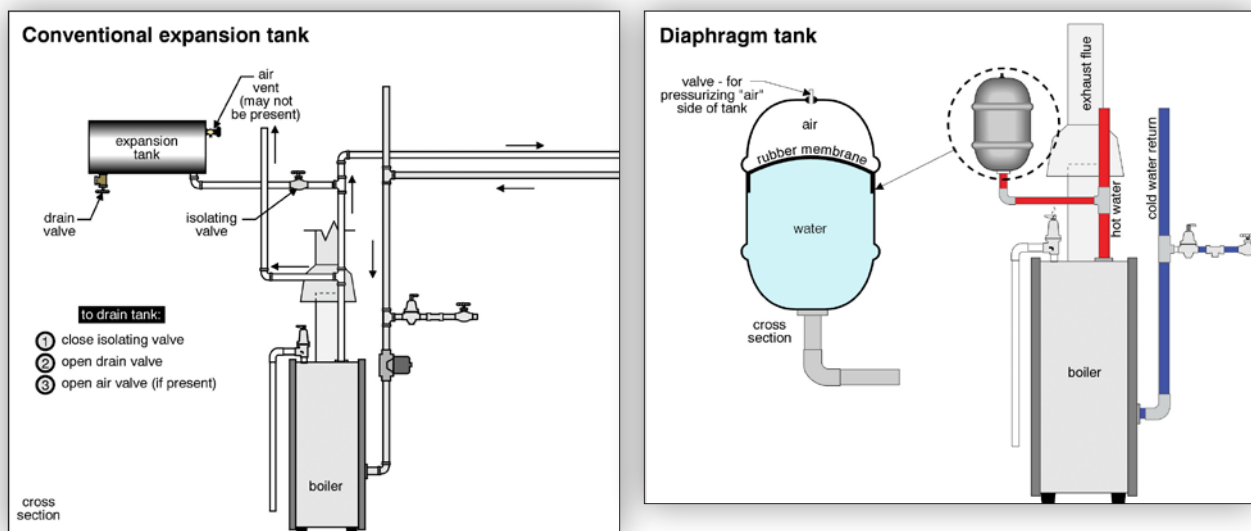

Common Problems with Expansion Tanks

TANK WATERLOGGED If the expansion tank has no air in it, it has no capacity to accept more water and is said to be waterlogged. When the boiler heats the water, the pressure rises and the pressure relief valve operates. A leaking or dripping pressure relief valve may mean a waterlogged expansion tank.

LEAK/RUST Expansion tanks are typically made of steel and can rust and eventually leak.

6.6 Operating and Safety Controls

Hot water heating systems have several controls to ensure safety and proper operation.

DESCRIPTION 6.6.1 Pressure Reducing Valve (Water Make-up Valve):

On modern systems, water is automatically added to the system through a pressure reducing valve as needed. The valve connects the boiler to the house plumbing system. It is typically set at 15 psi (pounds per square inch). If the pressure in the heating system drops below 15 psi, the pressure reducing valve allows water in from the plumbing system. When the plumbing system is drained, there is a risk of unhealthy water from the heating system draining back into the plumbing system. Modern systems include a backflow preventer to keep this from happening.

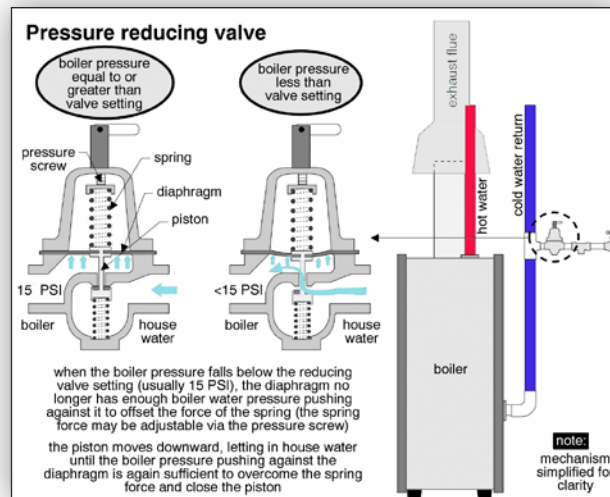

Common Problems with Pressure Reducing Valves

- LEAKS** The most common problems with pressure reducing valves are leakage and improper adjustment.
- DEFECTIVE** If the boiler is cold, the pressure gauge on the boiler should indicate roughly the same pressure as the pressure reducing valve (12-15 psi). If the two numbers are not the same, the pressure reducing valve may be out of adjustment or the pressure gauge may be wrong. There may also be a closed valve between the pressure reducing valve and gauge.
- SYSTEM NOT FILLED WITH WATER?** Sometimes the top floor of the home is cool, and radiators are not hot. If no water discharges after opening a radiator bleed valve on the top floor, the system is probably not full of water. There may not be enough pressure to push water up to the top of the home to fill the upper radiators. The pressure reducing valve may have to be adjusted or replaced.

DESCRIPTION 6.6.2 Backflow Preventer: The backflow preventer only allows water from the plumbing system to flow into the heating system. We don't want the dirty heating water from the boiler to get into our drinking water.

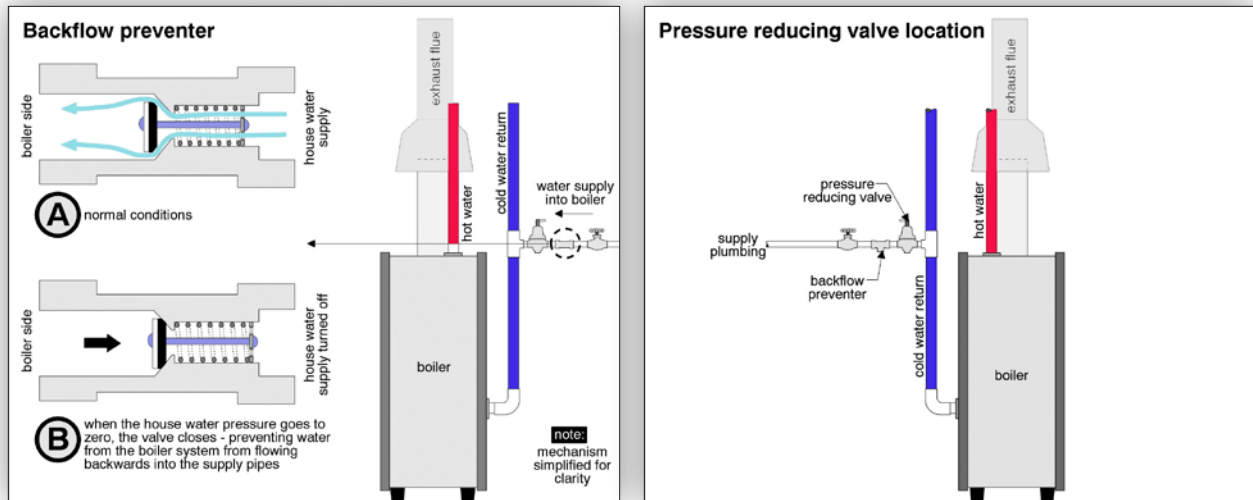

Common Problems with Backflow Preventers

MISSING/LEAKING A missing backflow preventer may represent a health hazard. The most common problem with backflow preventers is leakage.

6.6.3 Low Water Cut Out: Low water cut outs are provided on large boilers. They are designed to shut the heating system off if the boiler water level drops below a safe level. This prevents the boiler from burning itself up.

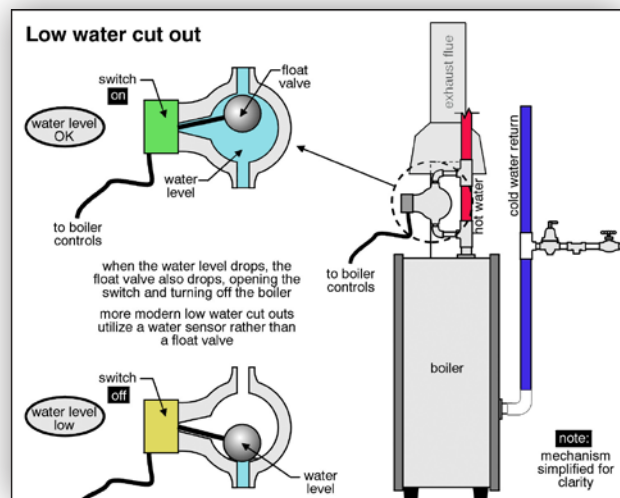

Common Problems with Low Water Cut Outs

LEAK/ INOPERATIVE Like most safety controls, the most common problem is leakage. It is also possible the low water cut out is inoperative, although this would not be discovered during a home inspection. This system should be tested during regular servicing.

6.6.4 High Temperature Limit:

The high temperature limit is a safety device that shuts off the boiler if the water temperature reaches roughly 200°F. The high temperature limit prevents the water from boiling. Boiling water builds up pressure, which may rupture the boiler or piping or possibly cause an explosion. This is not tested during a home inspection.

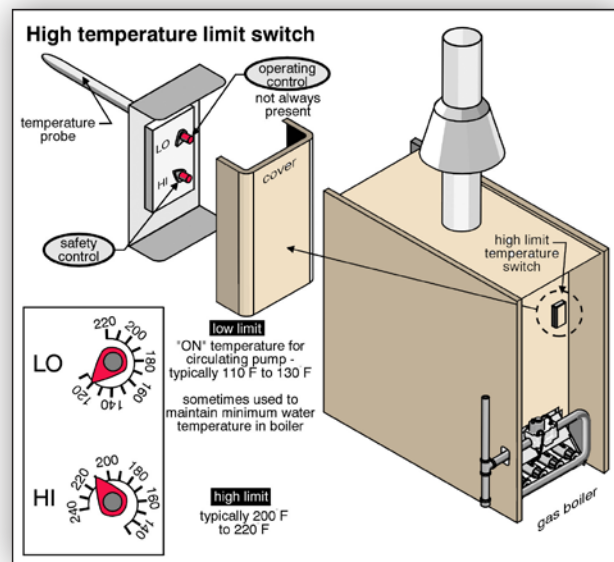

Common Problems with High Temperature Limit Switches

LEAKS/ DEFECTIVE/ ADJUSTMENT High temperature limit switches often leak where they are connected to the heating piping. The switch itself may require adjustment or repair. An inoperative high temperature limit switch may result in an unsafe situation, although they are designed to fail-safe and prevent the heating system from operating if they are defective. The high temperature limit is not tested during a home inspection.

6.6.5 Pressure Relief Valve: All boilers should be provided with pressure relief valves. The valves are typically set at about 30 psi. If the pressure in the boiler gets too high, this valve will allow the pressure to escape safely by releasing water. This device should be tested by a technician during regular servicing since it is not tested during a home inspection.

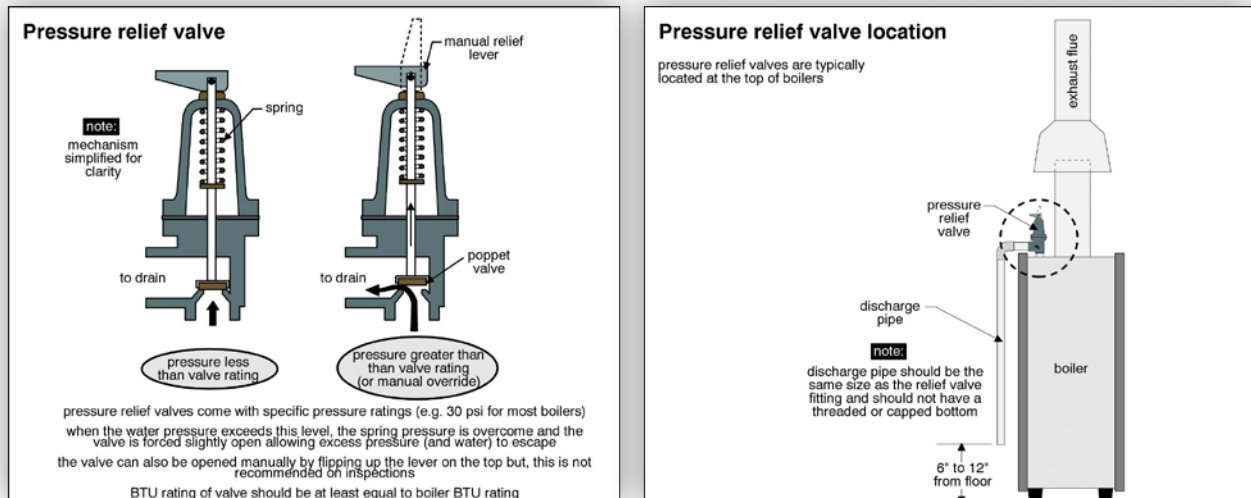

Common Problems with Pressure Relief Valves

- POOR DISCHARGE POINT** Because the water discharging from a pressure relief valve is very hot, the discharge should be piped down to six to 12 inches above the floor. This reduces the risk of scalding anyone nearby. If no pipe has been connected to the relief valve, there may be a dangerous situation.
- LEAKS** Pressure relief valves often leak. Sometimes this is due to a defective valve seat or debris caught on the valve seat. These nuisance problems are easily rectified. A leaking pressure relief valve may suggest a waterlogged expansion tank that allows pressure to build up in the system when the water is hot.
- CAPPED OFF** Sometimes, pressure relief valves that leak chronically are capped off. This should never be done, as the relief valve is an essential safety device.

6.7 Piping and Radiators, Convectors and Baseboards

DESCRIPTION Water heated in the boiler is distributed through the house. Cast iron radiators are common in older homes.

CONVECTORS Hot water convectors are an alternative to radiators. Convectors may be cast iron or copper tubing with aluminum fins. Radiators are typically 24 to 36 inches high. Convectors take up less space, usually being less than 12 inches high.

BASEBOARDS There are low profile baseboard hot water distribution systems. The piping can be steel, copper or polybutylene (PB).

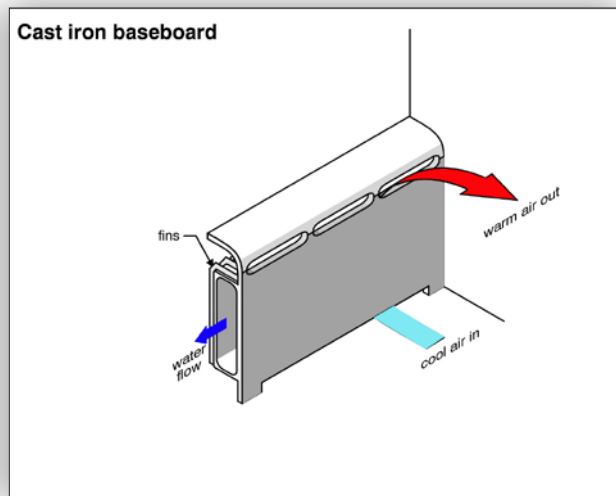
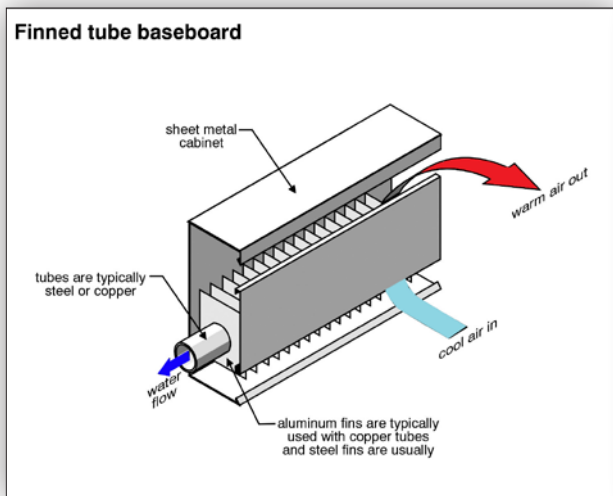
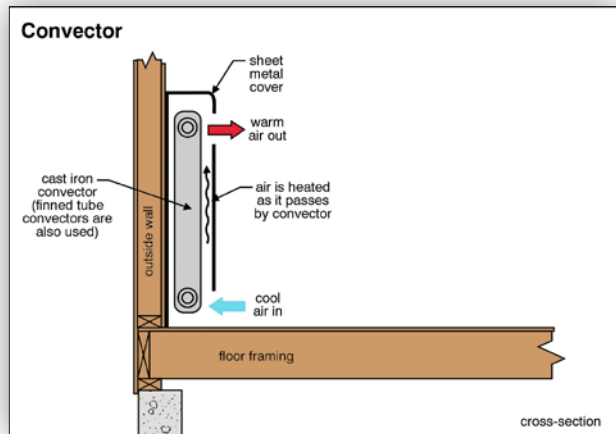
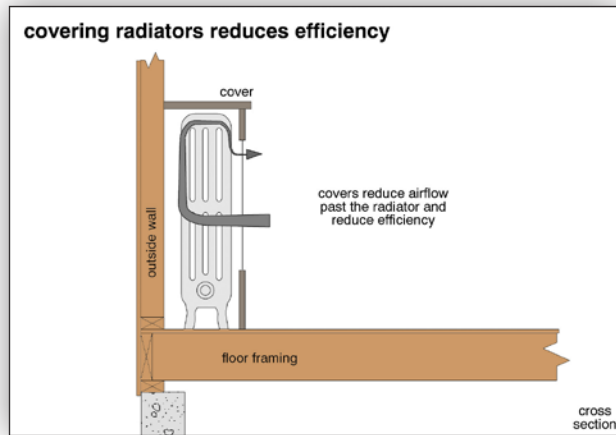

Common Problems with Radiators/Convectors

- MISSING** At least one radiator or convector should be provided in each habitable room. These are sometimes removed to make room for kitchen cabinets, for example. It is often easier and less expensive to install an electric baseboard heater than to re-install a radiator. The same is true if relocating a radiator. It may be best to remove it and replace it with electric heat.
- AIR IN THE SYSTEM** If air is trapped in a radiator, the radiator will not heat properly, because the radiator does not fill with water. Trapped air can be released through the bleed valve. If the radiators on the top floor of a home are not filled with water because there is not enough pressure in the system, these radiators will be cold. Adding more water to the system by changing the setting of the automatic water makeup valve usually resolves the problem.
- LEAKS** Other problems include leaks caused by failed packing at the control valves, or cracking of the radiator itself if the water in the system freezes.
- MIXED SYSTEM** Cast iron radiators and convectors take a long time to heat up, and a long time to cool down. This helps to produce even heat. Light weight convectors heat up and cool down quickly. Either system is fine, because the thermostat moderates the heat. However, uneven heating and comfort problems may be noticed where radiators and convectors are mixed in the same house.
- OBSTRUCTED** Radiators and convectors respond more slowly if air movement around them is obstructed. Some radiator covers reduce both effectiveness and efficiency. If radiators cannot give their heat off to house air that circulates freely, they may direct heat through the outside walls, effectively wasting it. Reflective materials (aluminum foil-faced insulation boards, for example) behind radiators help direct heat into the living area.
- DESCRIPTION** **6.7.1 Piping:** The piping on most hot water heating systems is black steel (not galvanized); however, some modern systems have copper or plastic piping, either polybutylene (PB) or cross-linked polyethylene (PEX). This piping distributes water to and from the boiler to the radiators or convectors. The piping may also be used as part of a radiant heating system.

Common Problems with Piping

- CORROSION** Steel piping corrodes, but the rate of deterioration is slow as the water within the heating system is rarely replaced. The water becomes chemically inert and the rusting process is slow. Draining the water from a heating system every summer is not recommended, since the pipes will deteriorate more quickly if the water is changed regularly.
- FAILED FITTINGS** Polybutylene (PB) piping is used in some hot water heating systems. Although there have been some issues with polybutylene plumbing piping and failed plastic fittings, this has not been a big issue on hot water heating systems. There are however, issues to be aware of with PB in baseboard systems.

POLYBUTYLENE BASEBOARD SYSTEMS – LEAKS The use of polybutylene (PB) piping for hot water heating in a baseboard convector configuration is not considered good practice. The connections are prone to leakage due to the cycling of pressure and water temperature. The piping is rated for 180°F, and the water temperature can exceed that.

6.7.2 Control Valves and Bleed Valves: Most radiators or convectors have a control valve that can be used to adjust the rate of water flow through the unit. This can be used to balance the heat in the home.

BLEED VALVES A small bleed valve is located near the top of the radiator. This allows trapped air in the radiator to be removed. Bleeding the radiators is part of annual maintenance.

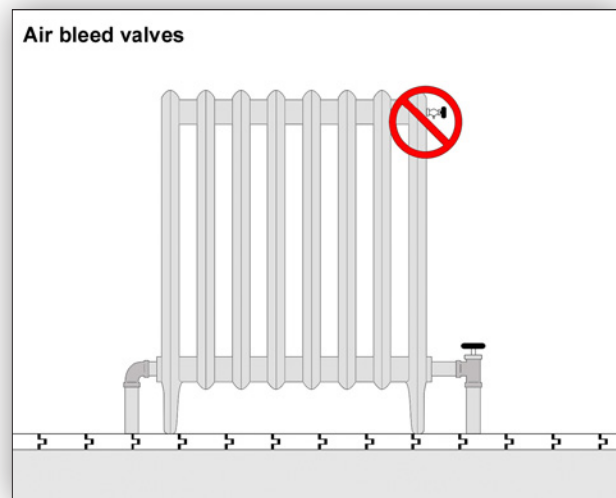

Common Problems with Control Valves and Bleed Valves

CONTROL VALVE – LEAKS/ INOPERATIVE Control valves are rarely used and, consequently, they often leak when they are turned. These valves are not operated during a home inspection. These valves are often inoperative or at least very difficult to move.

Even undisturbed valves are prone to leakage over time. The damage from a leaking valve can be extensive.

BLEED VALVE – DAMAGE/SEIZED/ LEAKS Bleed valves are delicate and easily broken. The very small valve openings can be obstructed by dirt or paint. They are prone to seizing or leaking; however, they are easily replaced. This requires at least partial draining of the system. Inoperative bleed valves don't allow air to be removed from radiators, and heating may be inadequate.

DESCRIPTION **6.7.3 Zone Valves:** Some sophisticated hot water heating systems have different areas of the house controlled by different thermostats. These thermostats operate motorized valves that open and close to direct hot water to specific areas of the house.

Another way to get zone control is with multiple circulating pumps. The thermostats control different pumps, directing water to specific zones, on demand.

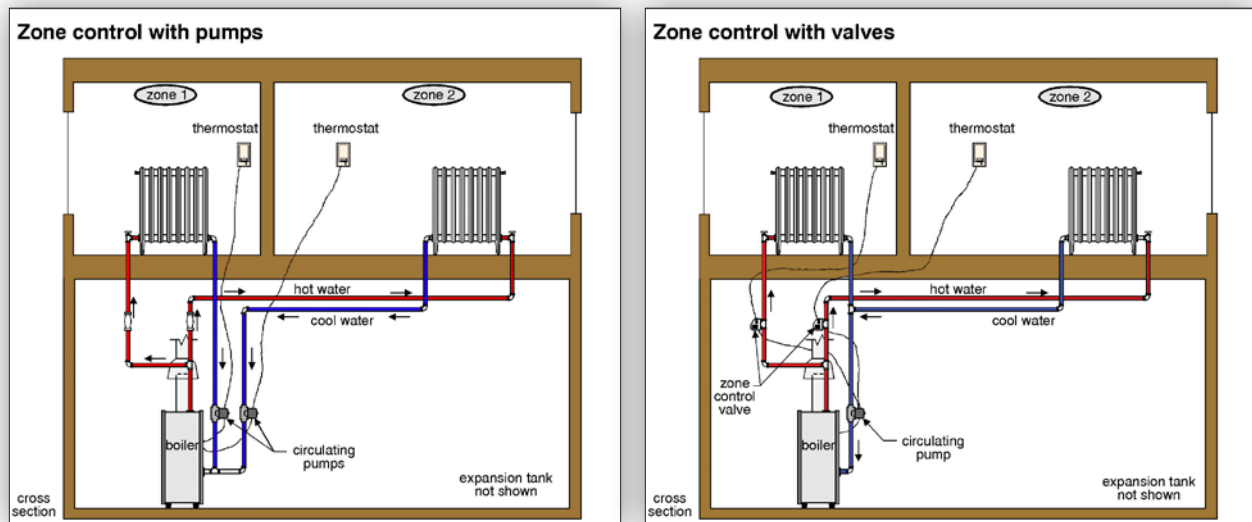

The Common Problem with Zone Valves and Pumps

INOPERATIVE Maintenance on these valves is frequently neglected and they are often abandoned. Pumps may be inoperative because the pump itself has seized or because the electric motor has failed. It is not possible during an inspection to verify the proper operation of zoned systems.

6.8 Radiant Hot Water Systems

DESCRIPTION Some hot water heating systems employ piping buried in floors or ceilings. The piping heats the floor or the ceiling, which in turn radiates the heat into the room. The pipes have traditionally been galvanized steel, black steel, or copper, although flexible plastic tubing is now used.

The pipes may be buried about three inches below the surface of concrete flooring and are typically four to 12 inches apart. Piping may also be set between the subfloor and flooring, often held in place with a special grid. In some cases, a foil reflector helps direct heat up into the room. Radiant piping can also be placed below the subfloor, running between the floor joists.

The temperatures in radiant heating systems are typically much lower than conventional radiator or convector systems. Water temperatures are typically maintained around 115°F, so that flooring is not overheated.

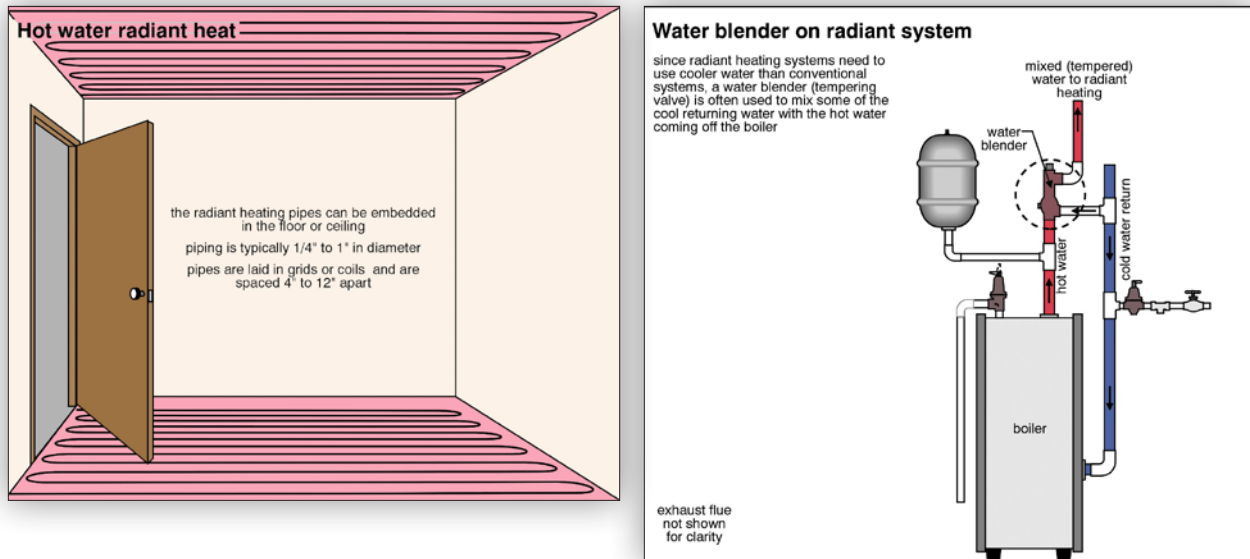

Many radiant systems have several discrete loops feeding different parts of the home, fed from a single manifold at the boiler. This approach is sometimes called a home run.

POLYBUTYLENE (PB) AND PEX Polybutylene (PB) piping is used in radiant heating systems extensively in some areas. Cross-linked polyethylene (PEX) piping is also used for radiant heating systems.

Common Problems with Radiant Hot Water Systems

LEAKS/ OBSTRUCTIONS Leakage can be a significant problem with hot water radiant systems. When a leak occurs, it is usually easily located due to the obvious water damage, unless the leak is below the basement or slab-on-grade floor. The piping can be crimped or obstructed, although this is less common. It may be difficult to find the problem.

TOO DEEP/ POORLY SPACED Heating pipes can be buried too deep (more than three inches) in concrete floors, resulting in slow response to the thermostat and some heat loss. There may be unwanted fluctuations in temperature. Hot spots and cold spots are often noted if pipes are too far apart (more than eight to 16 inches).

BREAKS/LEAKS These systems are susceptible to building settlement, and especially with steel or copper, the pipes can be broken as the house moves.

- OXYGEN PERMEATION THROUGH PB PIPING CAUSES RUSTING** When non-oxygen barrier polybutylene (PB) tubing is used in a hot water heating system, oxygen may pass through the tubing into the boiler water. This can cause the boiler to rust and fail prematurely. The condition of the boiler interior cannot be determined by a visual inspection. It is recommended that a heating specialist evaluate the system to determine whether improvements are needed. These could include adding a chemical to the system to discourage corrosion or adding a second heat exchanger system to separate the boiler water from the water circulating through the system. The heat exchanger option is costly but needs less maintenance.
- CONDENSATE SYSTEM – LEAKING/ CLOGGED** High-efficiency boilers have condensate that must be collected and disposed of, just like high-efficiency furnaces. In some jurisdictions, the condensate must be neutralized, so that the city piping is not attacked by the slightly acidic water. A leaking or clogged condensate system may damage the boiler or the home.

6.9 Boiler Efficiencies

Conventional boilers are roughly 60% seasonally efficient. More modern mid-efficiency boilers are roughly 80% seasonally efficient. There are very few high-efficiency boilers with efficiencies of up to 90%.

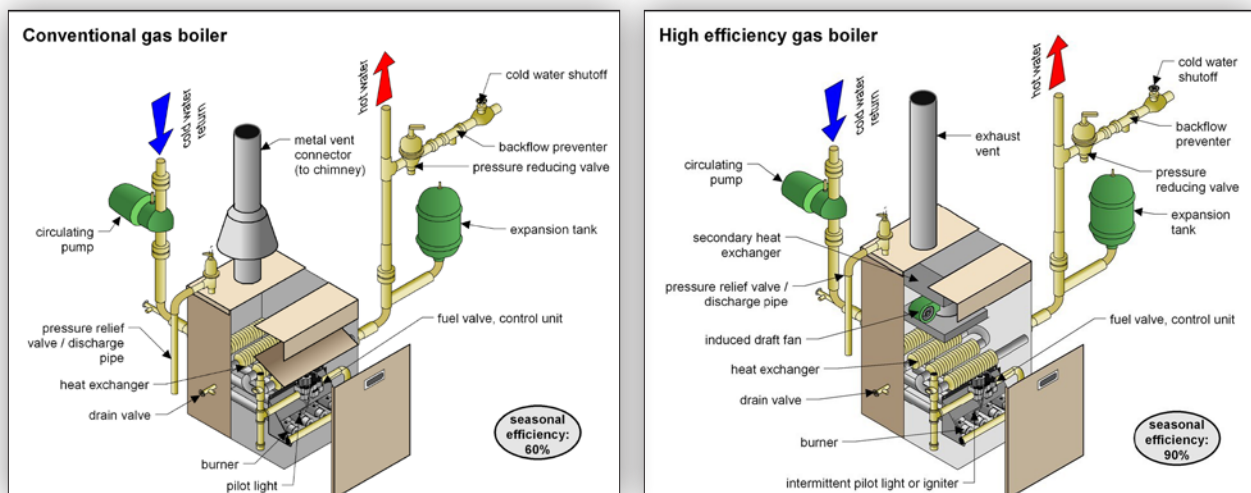

6.10 Boiler Life Expectancy

Conventional and mid-efficiency cast-iron boilers – 25 to 50 years

Conventional and mid-efficiency steel boilers – 20 to 35 years

Conventional and mid-efficiency copper boilers – 15 to 25 years

7.0 Steam Boilers

DESCRIPTION Steam boilers are similar to hot water boilers, typically made of cast iron or steel. As with hot water boilers, cast iron systems last longer than steel. Generally speaking, a hot water boiler may be expected to last slightly longer than a steam boiler made of the same material. Typical fuels are gas or oil, similar to a hot water boiler.

Unlike hot water heating systems, the radiators, piping and the top section of a steam boiler are filled with air when the boiler is at rest. When the boiler comes on and steam is generated, the steam moves through the system displacing the air. The air is released through air vents on the radiators or on the piping system. As the steam hits the relatively cold surface of the radiators, it condenses, giving up its heat to the radiators. The heat is transferred from the radiators into the room, similar to a hot water system. The condensed water flows back to the boiler to be reheated.

Steam systems are specialized, very complicated, and there are many variations. A complete inspection of the steam heating system is beyond the scope of most home inspections.

How steam systems work

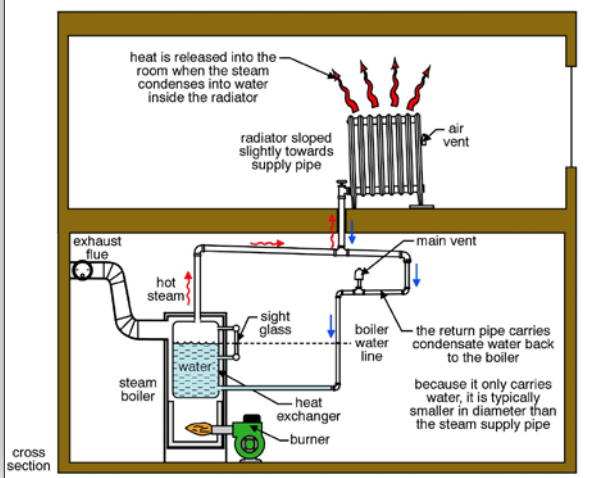

Steam system operation: at rest

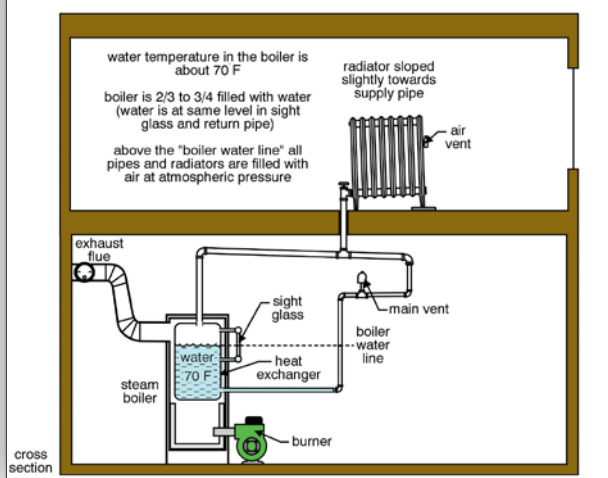

ONE-PIPE SYSTEMS A one-pipe steam system has a single pipe attached to each radiator. Steam moves through this pipe to the radiator, and the condensate flows back to the boiler through the same pipe. One-pipe systems cannot be converted to a hot water system without the addition of a second pipe.

TWO-PIPE SYSTEMS The two-pipe system has one pipe for carrying steam to the radiator, and a smaller pipe for returning condensate water to the boiler. Two-pipe systems can be converted to hot water, which may yield more efficient heating, and better control. Conversion can be tricky, and problems can be encountered if the work is not done professionally. A specialist should be consulted.

Two-pipe systems are considered more economical to operate than one-pipe systems.

RADIATORS The radiators are typically provided with a supply valve that can be opened or closed, and may have an air vent or a steam trap. Sophisticated and relatively expensive supply valves are thermostatically controlled, and may allow zone control of the heating. Steam radiators can be much hotter than hot water rads.

PRESSURETROL The steam boiler has three primary safety controls. The pressuretrol is both an operating device and a safety device. It triggers the burner when the thermostat is calling for heat and when the steam pressure is low, and cuts the burner out when the pressure is high. The pressuretrol is the first device that should shut off the burner with rising steam pressure. Rising steam pressure can be very dangerous, leading to a steam explosion.

One pipe parallel flow system

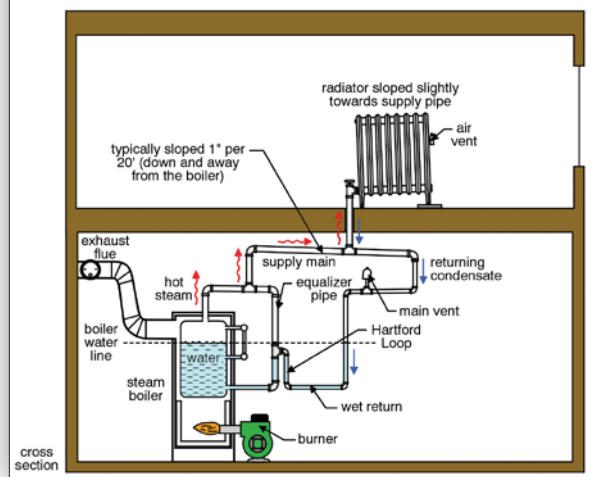

Two pipe system

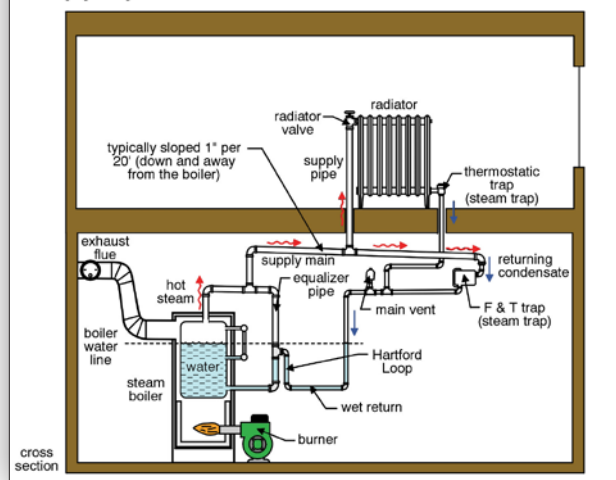

LOW WATER CUT OUT The low water cut out shuts off the burner if the boiler water level drops too low. It can be mounted inside or outside the boiler. Externally-mounted low water cut outs typically have a blowdown valve that allows them to be tested. Some manufacturers recommend monthly testing.

PRESSURE RELIEF VALVE The pressure relief valve senses the steam pressure at the top of the boiler and discharges steam to relieve pressure if it gets too high.

OTHER CONTROLS Other controls include water level and pressure gauges to monitor the operation of the system. There is also a manual or automatic water make-up valve so that water can be added to the system.

HARTFORD LOOP The Hartford Loop and equalizer pipe prevent the water level in the boiler from dropping as a result of a leak in a return pipe or a pressure imbalance between the supply and return piping side of the boiler. The Hartford Loop is somewhat redundant to the low water cut out, but is required in many jurisdictions.

SUMMARY A steam boiler should be fully serviced by a specialist on a regular basis. It is important that the homeowner know how to maintain the system and that the maintenance procedures be followed.

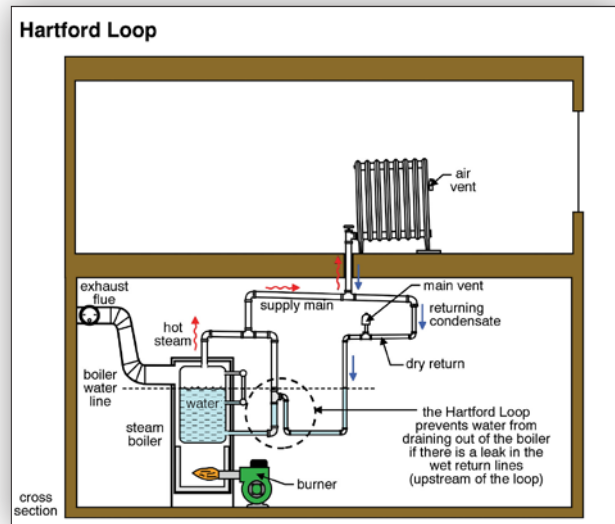

Common Problems with Steam Heating Systems

Steam heating systems have many of the same components as hot water boilers, and are subject to many of the same problems. There are also some problems specific to steam systems.

AIR VENTS Obstructed air vents will prevent the system from heating up. Air vents stuck in the open position will be inefficient and can be dangerous as steam is released directly into the room.

LEAKS If the water level in the system drops, the boiler may crack as it overheats. If the system floods with water, the piping and radiator systems may allow water to leak out.

STEAM TRAP If the steam trap fails in the open position, the system will be inefficient and the house will be uncomfortable. Similarly, if the steam trap is clogged, steam may be unable to move properly through the pipes and radiators.

LOW WATER CUT OUT PROBLEMS If the blow-off for the low water cut-out is not tested regularly, the cut-out may not operate properly and may fail to shut the boiler off in a low water situation. This is an unsafe situation.

PIPE SLOPE If the pipe slope is incorrect due to poor installation or building settlement, the system can be very noisy and heat distribution can be very uneven.

HIGHLIGHTS ONLY These are only the common problems associated with steam systems. The list is by no means exhaustive. Since steam boilers are, for the most part, older, the availability of parts can be a problem. A specialist should be engaged to inspect and maintain a steam heating system.

8.0 Electric Heat

We have touched on electric furnaces and boilers in the Furnace and Boiler sections. Here we will look at space heaters and radiant heat.

8.1 Electric Space Heaters

DESCRIPTION Some houses are heated entirely by electric heaters. Others use electric heat as a supplement to the main heating source. With the exception of electric furnaces and boilers (which are discussed elsewhere), electric heating systems are individual rather than central. In other words, the heat is generated within the room or space to be heated, and there is no distribution system – piping or ductwork. The most common type of electric room heater is the baseboard heater. Heaters with fans can also be installed in the floors, walls and ceilings, for example. The best place for a heater is in the coolest part of the room.

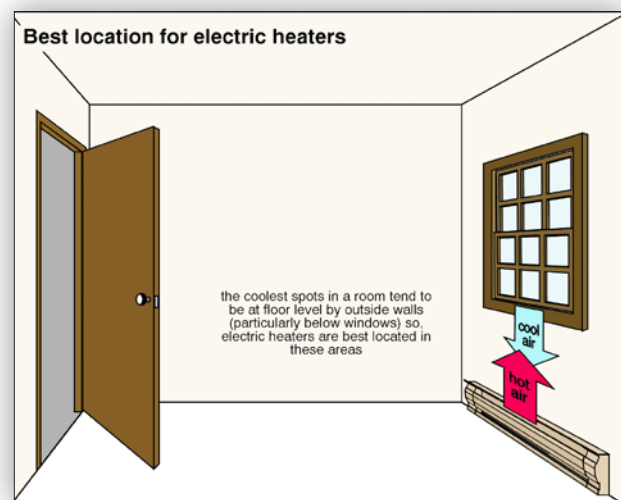

THERMOSTAT The thermostat can be directly on the units or mounted on a wall in the room. Wall thermostats may control one or more heaters. Wall mounted thermostats tend to be the preferred (and more expensive) method as they are easier to reach and, according to some, more accurate.

Common Problems with Electric Heaters

- OBSTRUCTED** Floor mounted heaters may be covered with rugs or mats, particularly during the summer. Blocking the airflow may lead to overheating.
- COMBUSTIBLE CLEARANCES** The manufacturer's recommendations for clearance from combustible materials should be followed. Draperies, for example, should typically be kept eight inches above the heaters. Alternatively, the drapes can be three inches in front of the heaters as long as they are at least one inch above the floor.
- Electrical receptacles should not be installed on the wall above an electric heater because appliance cords may touch the heater and overheat.
- DAMAGE** Electric heaters are vulnerable to mechanical damage, such as bent fins, and are prone to rust when installed in damp or wet areas. Rust, dirt and damage can impair performance and lead to failure.
- WIRED INCORRECTLY** Heaters designed to operate at 240 volts can be incorrectly wired at 120 volts. They will not work as efficiently as they should. This will not normally be picked up on a home inspection.
- INOPERATIVE – RUST/DAMAGE/ OVERHEATING** Rust, damage and overheating will ultimately lead to an inoperative heater. Generally, this requires replacement of the heater. Where evidence of overheating is noted, a specialist should be consulted promptly.

8.2 Electric Radiant Heat

DESCRIPTION Electric radiant systems are common in ceilings and floors. Wires may be embedded in the ceiling or laid in the floor. Some systems employ pre-wired panels or mats. The ceiling or floor will be warm but not hot to the touch when operating. Many radiant floor systems make the floor more comfortable but are not intended to be the only heat source in the room.

With any radiant heating system, care must be taken not to damage the system when drilling holes or mounting things such as light fixtures. Special patching materials are available for treating cracks and other flaws in heated ceilings.

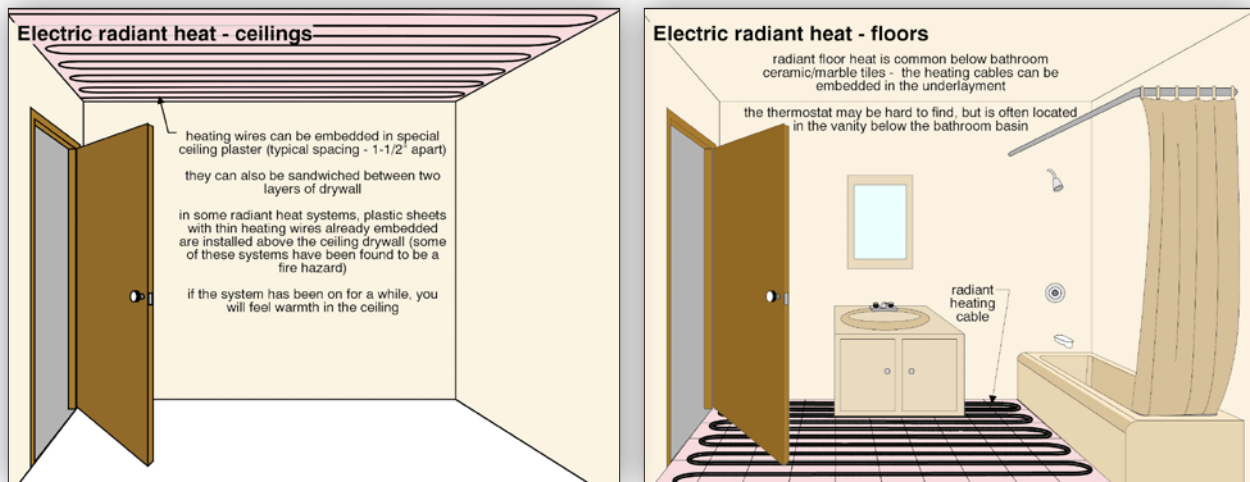

Common Problems with Electric Radiant Heating

- INOPERATIVE** In radiant heating systems, if the distribution wire itself malfunctions (breaks), it is often difficult to locate the problem in the wiring. There is special equipment to locate the problem. In many cases however, these systems are abandoned when they fail, and are replaced with electric baseboard heaters.
- SHADOW EFFECT** One common complaint about radiant heating systems is the shadow effect. Since radiant heat works the same way as sunlight, some people's legs feel cool if, for example, they are sitting at a dining room table for several hours. The table shades their legs from the direct radiant heat.

9.0 Failure Probability

Every boiler or furnace contains several components that may cause the system to stop operating. For example, if an inexpensive thermocouple fails on a gas-fired furnace, the pilot will shut off. With the pilot shut off, the furnace will not operate. This is easy to repair. We think of failure as having to replace the whole furnace or boiler, for example.

- HEAT EXCHANGERS FOR FURNACES AND BOILERS** For most furnaces and boilers, terminal failure is usually a crack or a hole in the heat exchanger. Since most of the heat exchanger is not visible, the heat exchanger cannot be fully inspected during a home inspection. Because a home inspection is not technically exhaustive, the likelihood of failure is based on probability rather than testing or equipment tear-down.

A conventional gas-fired furnace, for example, contains a heat exchanger having an average life expectancy of 18 to 25 years. There are, however, manufacturers of gas-fired, forced-air furnaces whose heat exchangers have a reputation for failing sooner.

- RETROFIT ISSUES FOR HIGH EFFICIENCY FURNACES** Most high efficiency furnaces require more air flow across the heat exchangers than conventional furnaces. Replacing a conventional furnace with a high efficiency furnace can be tricky. Older, smaller ductwork and/or an air conditioning coil can restrict air flow, increasing the temperature rise within the furnace. This can result in premature failure of the heat exchangers and void the warranty. This condition may not be identified in a home inspection.
- LIFE EXPECTANCY OF STEAM BOILERS** Steam boilers are typically old and most are considered near the end of their life. Steam boilers have a heat exchanger, like hot water boilers and when this fails, the system is typically replaced.
- LIFE EXPECTANCY OF ELECTRIC SYSTEMS** Electric furnaces and boilers contain electric heating elements and controls for the elements. Every single component can be replaced. With age, however, electric systems get to a stage where replacement of the entire unit makes sense due to lost reliability and a lack of available replacement parts. Electric boilers have a water jacket that will eventually rust. Although there are not great statistics on these units, a life expectancy of 20 to 25 years may be reasonable.

With individual electric heaters, failure probability is not meaningful, since replacing individual heaters is not a significant expense. Electric heating elements are like light bulbs. Their life expectancy is not well defined, and their failure can't be predicted.

